

ELECTRONIC CASH REGISTER

# TE-2000

THANK YOU  
YOUR RECEIPT  
CALL AGAIN !

GROCERY  
DAIRY  
H. B. A.  
FROZEN  
FOOD  
DELICATESSEN



Eu Di U.K.

USER'S MANUAL

**CASIO**

---

## Safety Precautions

- To use this product safely and correctly, read this manual thoroughly and operate as instructed.  
After reading this guide, keep it close at hand for easy reference.  
Please keep all informations for future reference.
- Always observe the warnings and cautions indicated on the product.

## About the icons

In this guide various icons are used to highlight safe operation of this product and to prevent injury to the operator and other personnel and also to prevent damage to property and this product. The icons and definitions are given below.



Indicates that there is a risk of severe injury or death if used incorrectly.



Indicates that injury or damage may result if used incorrectly.

## Icon examples

To bring attention to risks and possible damage, the following types of icons are used.



The  $\triangle$  symbol indicates that it includes some symbol for attracting attention (including warning). In this triangle the actual type of precautions to be taken (electric shock, in this case) is indicated.



The  $\otimes$  symbol indicates a prohibited action. In this symbol the actual type of prohibited actions (disassembly, in this case) will be indicated.



The  $\bullet$  symbol indicates a restriction. In this symbol the type of actual restriction (removal of the power plug from an outlet, in this case) is indicated.

---

## Warning!

---

## Handling the register



**Should the register malfunction, start to emit smoke or a strange odor, or otherwise behave abnormally, immediately shut down the power and unplug the AC plug from the power outlet. Continued use creates the danger of fire and electric shock.**

- Contact CASIO service representative.



**Do not place containers of liquids near the register and do not allow any foreign matter to get into it. Should water or other foreign matter get into the register, immediately shut down the power and unplug the AC plug from the power outlet. Continued use creates the danger of shorting, fire and electric shock.**

- Contact CASIO service representative.



**Should you drop the register and damage it, immediately shut down the power and unplug the AC plug from the power outlet. Continued use creates the danger of shorting, fire and electric shock.**

- Attempting to repair the register yourself is extremely dangerous. Contact CASIO service representative.
-

---

## **Warning!**



**Never try to take the register apart or modify it in any way. High-voltage components inside the register create the danger of fire and electric shock.**

- Contact CASIO service representative for all repair and maintenance.
- 

### **Power plug and AC outlet**



**Use only a proper AC electric outlet (100V~240V) . Use of an outlet with a different voltage from the rating creates the danger of malfunction, fire, and electric shock. Overloading an electric outlet creates the danger of overheating and fire.**



**Make sure the power plug is inserted as far as it will go. Loose plugs create the danger of electric shock, overheating, and fire.**

- Do not use the register if the plug is damaged. Never connect to a power outlet that is loose.
- 



**Use a dry cloth to periodically wipe off any dust built up on the prongs of the plug. Humidity can cause poor insulation and create the danger of electric shock and fire if dust stays on the prongs.**



**Do not allow the power cord or plug to become damaged, and never try to modify them in any way. Continued use of a damaged power cord can cause deterioration of the insulation, exposure of internal wiring, and shorting, which creates the danger of electric shock and fire.**

- Contact CASIO service representative whenever the power cord or plug requires repair or maintenance.
- 

## **Caution!**



**Do not place the register on an unstable or uneven surface. Doing so can cause the register — especially when the drawer is open — to fall, creating the danger of malfunction, fire, and electric shock.**

**Do not place the register in the following areas.**



- Areas where the register will be subject to large amounts of humidity or dust, or directly exposed to hot or cold air.
- Areas exposed to direct sunlight, in a close motor vehicle, or any other area subject to very high temperatures.

**The above conditions can cause malfunction, which creates the danger of fire.**

---



**Do not overlay bend the power cord, do not allow it to be caught between desks or other furniture, and never place heavy objects on top of the power cord. Doing so can cause shorting or breaking of the power cord, creating the danger of fire and electric shock.**



**Be sure to grasp the plug when unplugging the power cord from the wall outlet. Pulling on the cord can damage it, break the wiring, or cause short, creating the danger of fire and electric shock.**



**Never touch the plug while your hands are wet. Doing so creates the danger of electric shock. Pulling on the cord can damage it, break the wiring, or cause short, creating the danger of fire and electric shock.**

**Never touch the printer head and the platen.**

---

# Introduction & Contents

---

<b>Introduction &amp; Contents .....</b>	<b>4</b>
<b>Getting Started .....</b>	<b>7</b>
Remove the cash register from its box. ....	7
Remove the tape holding parts of the cash register in place. ....	7
Install the three memory backup batteries. ....	7
Install receipt/journal paper. ....	9
Plug the cash register into a wall outlet. ....	11
Insert the mode key marked "PGM" into the mode switch. ....	11
Turn the mode key to the "REG" position. ....	11
Set the date. ....	12
Set the time. ....	12
Tax table programming .....	13
<b>Introducing TE-2000 .....</b>	<b>17</b>
General guide .....	17
Roll paper, Receipt On/Off key, Mode key, Drawer, Drawer lock .....	17
Mode switch .....	18
Lock/unlock the multipurpose tray .....	18
Displays .....	19
Keyboard .....	20
<b>Basic Operations and Setups .....</b>	<b>22</b>
How to read the printouts .....	22
How to use your cash register .....	23
Displaying the time and date .....	24
Preparing coins for change .....	24
Preparing and using department keys .....	25
Registering department keys .....	25
Programming department keys .....	26
Registering department keys by programming data .....	27
Preparing and using PLUs .....	28
Programming PLUs .....	28
Registering PLUs .....	29
Preparing and using discounts/premiums .....	30
Programming discounts/premiums .....	30
Registering discounts/premiums .....	31
Preparing and using reductions .....	32
Programming for reductions .....	32
Registering reductions .....	33
Registering charge and check payments .....	34
Registering returned goods in the REG mode .....	35
Registering returned goods in the RF mode .....	36
Registering money received on account .....	37
Registering money paid out .....	37
Making corrections in a registration .....	38
No sale registration .....	40
Printing the daily sales reset report .....	41
<b>Convenient Operations and Setups .....</b>	<b>42</b>
Clerk control function .....	42
Clerk sign on and sign off .....	42
Post-finalization receipt format, General printing control, Compulsory, Machine features ..	43
About post-finalization receipt .....	43

Programming general printing control .....	44
Programming compulsory and clerk control function .....	45
Programming read/reset report printing control .....	46
Setting a store/machine number .....	46
Programming to clerk .....	47
Programming clerk number .....	47
Programming trainee status of clerk .....	47
Programming descriptors and messages .....	48
Programming report descriptor, grand total, special character, report title, receipt message and clerk name .....	48
Report descriptor .....	48
Grand total, special character .....	49
Report title .....	49
Clerk name .....	49
Receipt message .....	50
Programming department key descriptor .....	50
Programming PLU descriptor .....	51
Programming function key descriptor .....	52
Programming receipt message/logo stamp control function .....	52
Entering characters .....	53
Using character keyboard .....	53
Entering characters by code .....	54
Department key feature programming .....	55
Batch feature programming .....	55
Individual feature programming .....	56
PLU feature programming .....	57
Batch feature programming .....	57
Individual feature programming .....	58
Printing VAT breakdowns .....	61
Currency exchange programming .....	62
Currency exchange rate programming .....	62
Currency exchange feature programming .....	62
Other function key feature programming .....	65
Cash, Charge, Check key .....	65
Minus key, Discount key and premium key .....	66
Received on account, Payout key, #/No sale key .....	66
Calculator functions .....	67
About the daylight saving time .....	68
Printing read/reset reports .....	69
Reading the cash register's program .....	75
<b>Troubleshooting .....</b>	<b>78</b>
When an error occurs .....	78
When the register does not operate at all .....	79
In case of power failure .....	80
When the L sign appears on the display .....	80
<b>User Maintenance and Options .....</b>	<b>81</b>
To replace journal paper .....	81
To replace receipt paper .....	82
Options .....	82
<b>Specifications .....</b>	<b>83</b>
<b>Index .....</b>	<b>84</b>

## Unpacking the register

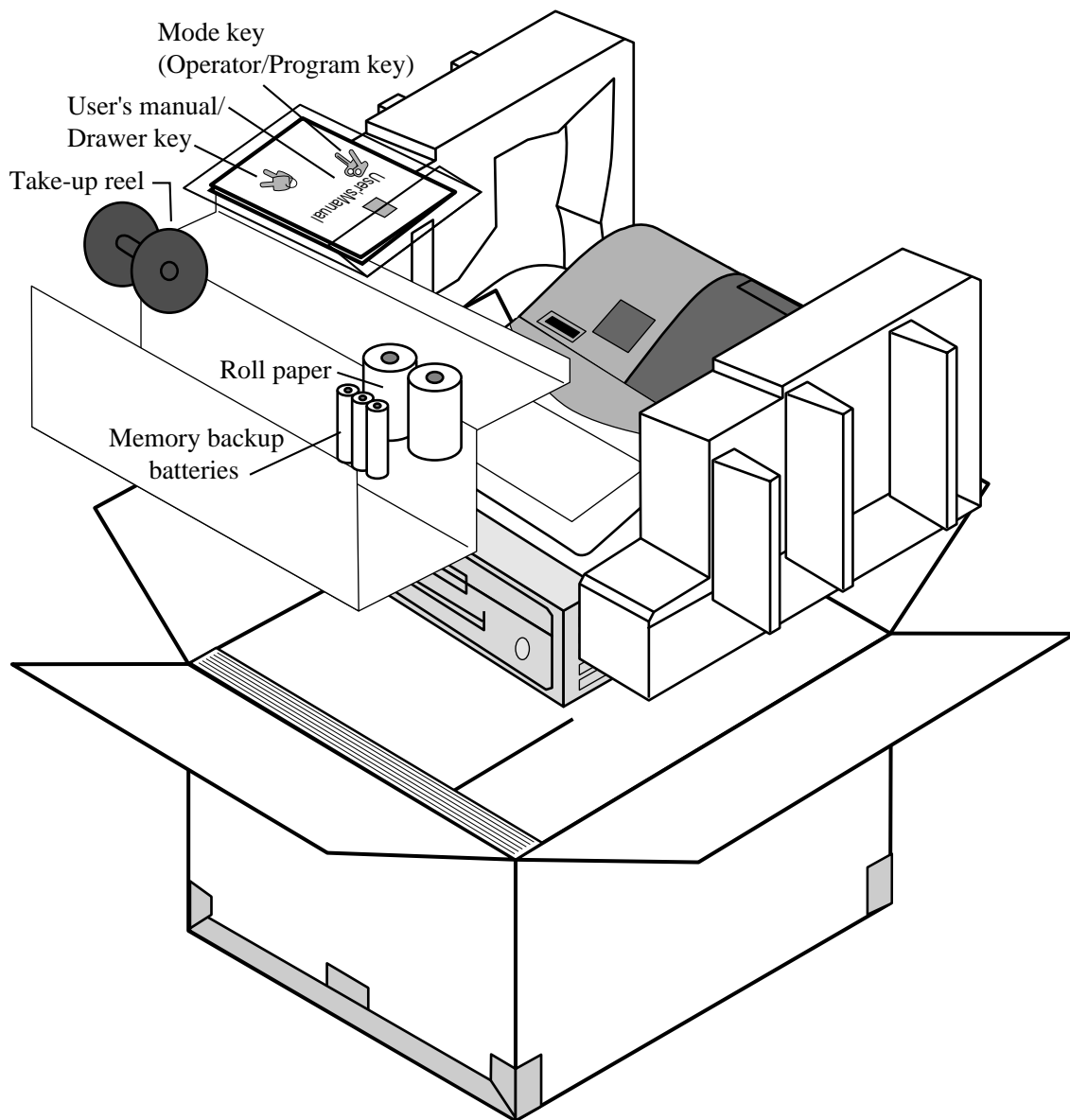

### Welcome to the CASIO TE-2000!

Congratulations upon your selection of a CASIO Electronic Cash Register, which is designed to provide years of reliable operation.

Operation of a CASIO cash register is simple enough to be mastered without special training. Everything you need to know is included in this manual, so keep it on hand for reference.

Consult your CASIO dealer if you have any questions about points not specifically covered in this manual.

The main plug on this equipment must be used to disconnect main power.

Please ensure that the socket outlet is installed near the equipment and shall be easily accessible.

*Please keep all information for future reference.*

# Getting Started

This section outlines how to unpack the cash register and get it ready to operate. You should read this part of the manual even if you have used a cash register before. The following is the basic set up procedure, along with page references where you should look for more details.

- 1. Remove the cash register from its box.**  
Make sure that all of the parts and accessories are included.

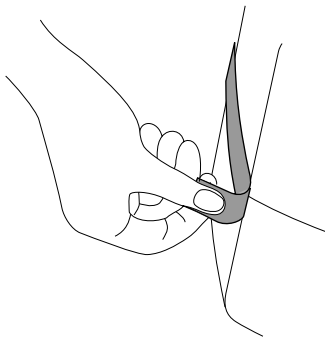
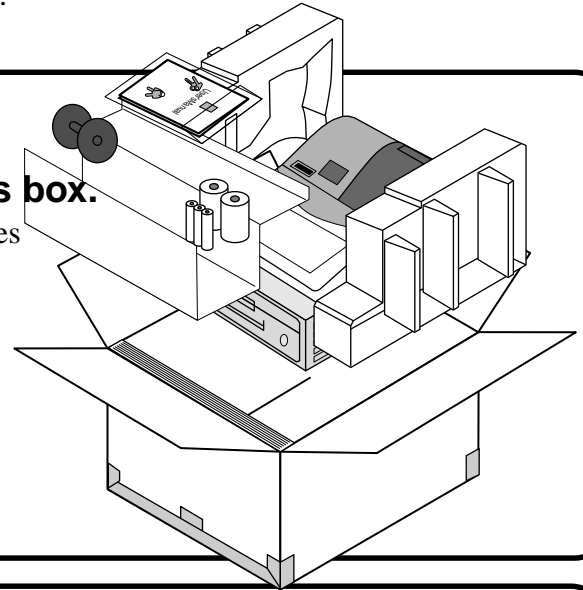

- 2. Remove the tape holding parts of the cash register in place.**

Also remove the small plastic bag taped to the printer cover. Inside you will find the mode keys.

- 3. Install the three memory backup batteries.**



printer cover

1. Remove the printer cover and open the platen arm.



platen arm



battery compartment cover

2. Remove the battery compartment cover. Slide the cover and pull it up.

## 3. Install the three memory backup batteries. (continued...)



3. Note the (+) and (-) markings in the battery compartment. Load a set of three new SUM-3 (UM-3) batteries so that their positive (+) and negative (-) ends are facing as indicated by the markings.



4. Replace the battery compartment cover.

5. Close the platen arm and replace the printer cover.

### Important!

These batteries protect information stored in your cash register's memory when there is a power failure or when you unplug the cash register. Be sure to install these batteries.

### Precaution!

Incorrectly using batteries can cause them to burst or leak, possibly damaging the interior of the cash register. Note the following.

- Be sure that the positive (+) and negative (-) ends of the batteries are facing as marked in the battery compartment when you load them into the unit.
- Never mix batteries of different types.
- Never mix old batteries with new ones.
- Never leave dead batteries in the battery compartment.
- Remove the batteries if you do not plan to use the cash register for long periods.
- Replace the batteries at least once a year, no matter how much the cash register is used during the period.

### WARNING!

- Never try to recharge the batteries supplied with the unit.
- Do not expose batteries to direct heat, let them become shorted or try to take them apart.

Keep batteries out of the reach of small children. If your child should swallow a battery, consult a physician immediately.

# 4. Install receipt/journal paper.

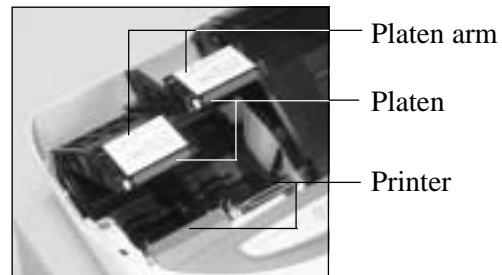

### Important!

Take away the head protection sheet from the printer and close the platen arm.

### Caution! (in handling the thermal paper)

- Never touch the printer head and the platen.
- Unpack the thermal paper just before your use.
- Avoid heat/direct sunlight.
- Avoid dusty and humid places for storage.
- Do not scratch the paper.
- Do not keep the printed paper under the following circumstances:  
High humidity and temperature/direct sunlight/contact with glue, thinner or a rubber eraser.

## To install receipt paper



*Step 1*  
Remove the printer cover.



*Step 4*  
Put the leading end of the paper over the printer.



*Step 2*  
Open the platen arm.



*Step 5*  
Close the platen arm slowly until it locks steadily.



*Step 3*  
Ensuring the paper is being fed from the bottom of the roll, lower the roll into the space behind the printer.



*Complete*  
Replace the printer cover, passing the leading end of the paper through the cutter slot. Tear off the excess paper.

## To install journal paper



### Step 1

Remove the printer cover.



### Step 2

Open the platen arm.



### Step 7

Slide the leading end of the paper into the groove on the spindle of the take-up reel and wind it onto the reel two or three turns.



### Step 3

Ensuring the paper is being fed from the bottom of the roll, lower the roll into the space behind the printer.



### Step 8

Replace the paper guide of the take-up reel.



### Step 4

Put the leading end of the paper over the printer.



### Step 9

Place the take-up reel into place behind the printer, above the roll paper.



### Step 5

Close the platen arm slowly until it locks steadily.



### Step 10

Press the **JOURNAL FEED** key to take up any slack in the paper.

During machine installation, press the **JOURNAL FEED** key after power on.



### Step 6

Remove the paper guide of the take-up reel.



### Complete

Replace the printer cover.

### 5. Plug the cash register into a wall outlet.

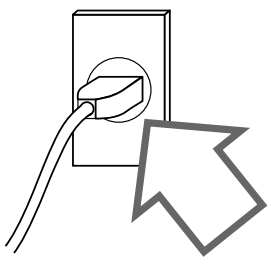

Be sure to check the sticker (rating plate) on the side of the cash register to make sure that its voltage matches that of the power supply in your area.

### 6. Insert the mode key marked "PGM" into the mode switch.

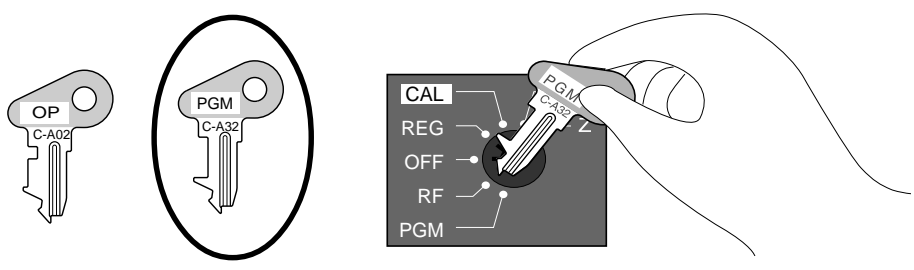

### 7. Turn the mode key to the "REG" position.

The display should change to the following.

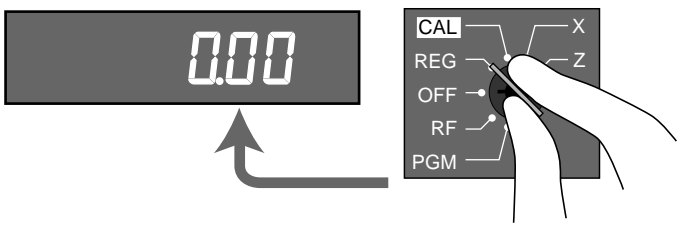

## 8. Set the date.

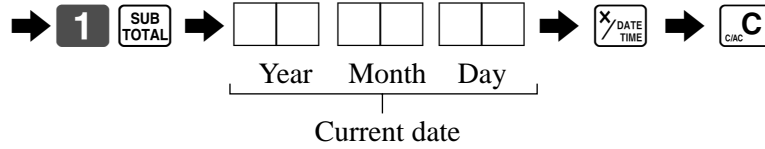
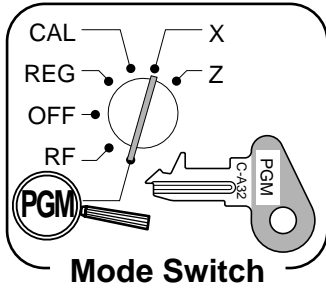

Example:

15, March 2002 ⇨ 0 2 0 3 1 5

## 9. Set the time.

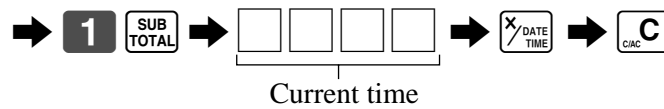
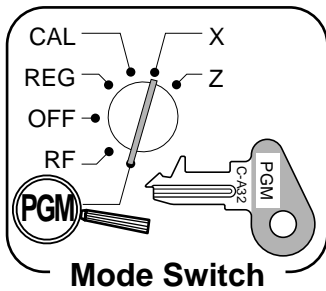

Example:

08:20 AM ⇨ 0 8 2 0

09:45 PM ⇨ 2 1 4 5

# 10. Tax table programming

This cash register is capable of automatically calculating up to four different sales taxes. The sales tax calculations are based on rates, so you must tell the cash register the rates, the type of tax (add-in or add-on), and the type of rounding to apply. Note that special rounding methods (page 15) are also available to meet certain local tax requirements.

## Important!

After you program the tax calculations, you also have to individually specify which departments (page 26) and PLUs (page 28) are to be taxed.

### Programming tax calculations (without special rounding)

Prepare the following subjects:

1. Tax rates
2. Rounding method for tax calculation  
(Round up/Round off/Cut off)
3. Tax calculation system (Add-on/Add-in)

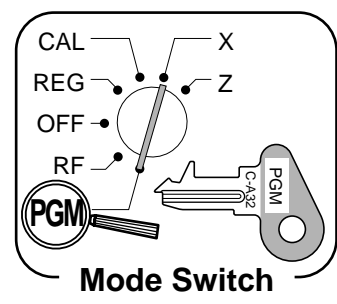

### Programming procedure

Assign tax table 1. ....>

- Assigning tax table 2, enter 0 2 2 5 .
- Assigning tax table 3, enter 0 3 2 5 .
- Assigning tax table 4, enter 0 4 2 5 .

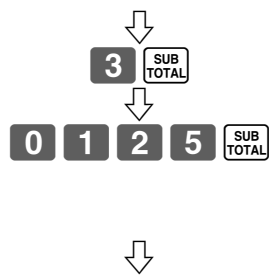

Enter tax rate (2 integers and 4 decimals)..

- Example: 15% = 1 5
- 8.25% = 8 . 2 5



Enter rounding method, tax calculation method..

Fraction round up	9	0		
Fraction round off	5	0		
Fraction cut off	0	0		
Always "0"			0	
Add-on tax				2
Add-in tax				3

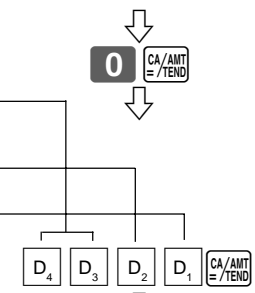

Terminate the procedure.. ....>



## 10. Tax table programming (continued...)

### Programming tax calculations (with special rounding)

Prepare the following subjects:

1. Tax rates
2. Rounding method for tax calculation (Round up/Round off/Cut off)
3. Tax calculation system (No/Add-on/Add-in)
4. Rounding system (Special rounding 1/Special rounding 2/Special rounding 3/Danish rounding /Australian rounding) :only effective for Tax Table 1

### Programming procedure

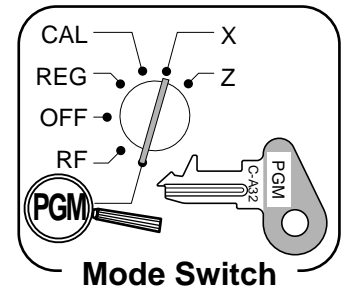

Mode Switch



Assign tax table 1. .... →

- Assigning tax table 2, enter **0 2 2 5**.
- Assigning tax table 3, enter **0 3 2 5**.
- Assigning tax table 4, enter **0 4 2 5**.

Enter tax rate (2 integers and 4 decimals)

- Example: 15% = **1 5**
- 8.25% = **8 . 2 5**
- non tax = **0**

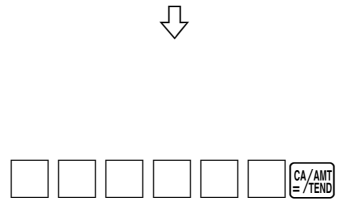

Enter rounding method, tax calculation method..

Fraction round up	9	0		
Fraction round off	5	0		
Fraction cut off	0	0		
Special rounding 1 *			1	
Special rounding 2 *			2	
Special rounding 3 *			6	
Special rounding 4 *			3	
Special rounding 5 *			7	
Add-on tax				2
Add-in tax				3

\* See the next page.

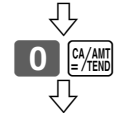

Terminate the procedure. .... →



# 10. About special rounding...

Besides cut off, round off and round up, you can also specify “special rounding” for subtotals and totals or changes. Special rounding converts the right-most digit(s) of an amount to “0” or “5” to comply with the requirements of certain areas.

## ① Special Rounding 1

Last (right-most) digit		Rounding result	Examples:
0 ~ 2	⇒	0	1.21 → 1.20
3 ~ 7	⇒	5	1.26 → 1.25
8 ~ 9	⇒	10	1.28 → 1.30

## ② Special Rounding 2

Last (right-most) digit		Rounding result	Examples:
0 ~ 4	⇒	0	1.12 → 1.10
5 ~ 9	⇒	10	1.55 → 1.60

## ③ Special Rounding 3

Last (right-most) 2 digits		Rounding result	Examples:
00 ~ 24	⇒	0	1.24 → 1.00
25 ~ 74	⇒	50	1.52 → 1.50
75 ~ 99	⇒	100	1.77 → 2.00

## ④ Special Rounding 4 (Danish Rounding)

With Danish rounding, the rounding method applies to subtotals depends on whether you finalize the transaction by inputting an amount tendered or not.

- When a finalization is performed without an amount tendered entry
- When a finalization is performed with an amount tendered entry

Last (right-most) 2 digits of subtotal		Rounding result	Last (right-most) 2 digits of change due		Rounding result
00 ~ 12	⇒	00	00 ~ 12	⇒	00
13 ~ 37	⇒	25	13 ~ 37	⇒	25
38 ~ 62	⇒	50	38 ~ 62	⇒	50
63 ~ 87	⇒	75	63 ~ 87	⇒	75
88 ~ 99	⇒	100	88 ~ 99	⇒	100

## ⑤ Special Rounding 5 (Australian Rounding)

Last (right-most) digit		Rounding result	Examples:
0 ~ 2	⇒	0	1.21 → 1.20
3 ~ 7	⇒	5	1.26 → 1.25
8 ~ 9	⇒	10	1.28 → 1.30



### • Partial tenders (payments): for Danish Rounding

No rounding is performed for the amount of tendered nor for the change amount due when the customer makes a partial tender. When a partial tender results in a remaining balance within the range of 1 through 12, the transaction is finalized as if there was no remaining balance.

### • Display and printing of subtotals: for Danish and Australian Rounding

When you press the  key, the unrounded subtotal is printed and shown on the display. If the cash register is also set up to apply an add-on tax rate, the add-on tax amount is also included in the subtotal that is printed and displayed.

### Important!

When you are using Danish rounding, you can use the  key to register tendered amount in which the last (right-most) digits are 00, 25, 50 or 75. This restriction does not apply to the  and  keys.

## 11. For Australia only

You can set some programmable options to suit the Australian GST by the following procedure.

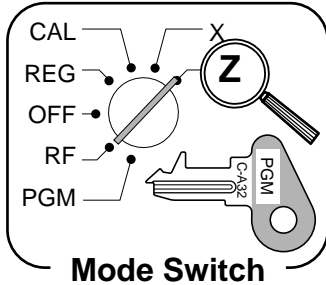

After completion of this procedure, the “GST system was changed” message was printed on receipt and;

- ① Tax symbol (\*) is printed.
- ② Taxable amount is skipped.
- ③ “GST INCLUDED” is set to the TX1 descriptor.
- ④ “TAXABLE AMT” is set to the TA1 descriptor.
- ⑤ Total line is printed even in direct (cash) sale.
- ⑥ Australian rounding is set.
- ⑦ “\$” is set to the monetary symbol.
- ⑧ Print “MOF message” on receipt.
- ⑨ Tax (10% tax rate, add-in tax, fraction round off) is set to the tax table 1.  
No data is set to other tax tables.
- ⑩ The taxable amount and tax amount except TA1/TX1 are not printed on report.
- ⑪ Restriction (to 0, 5) on last amount digit of cash sales, received on account, paid out, and money declaration.

# Introducing TE-2000

## General guide

This part of the manual introduces you to the cash register and provides a general explanation of its various parts.

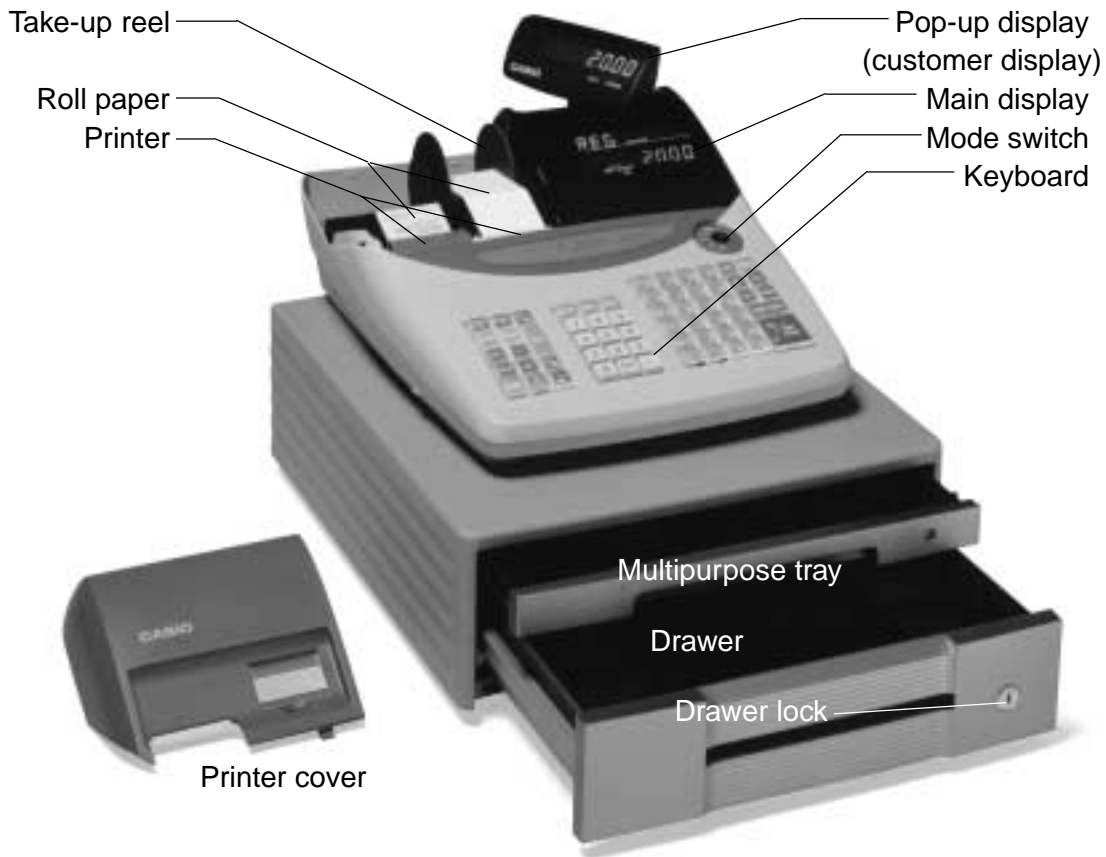

### Roll paper

You can use the roll paper to print receipts and a journal (page 9 ~ 10).

### Receipt On/Off key

When you are using the printer for receipt printer, you can use this key (in the REG and RF modes only) to turn the printer on and off. If a customer asks for a receipt while receipt printing is turned off by this key, you can issue a post-finalization receipt (page 43).

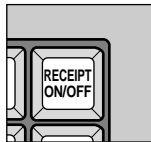

### Mode key

There are two types of mode keys: the program key (marked "PGM") and the operator key (marked "OP"). The program key can be used to set the mode switch to any position, while the operator key can select the **REG**, **CAL** and **OFF** position.

### Drawer

The drawer opens automatically whenever you finalize a registration and whenever you issue a read or reset report. The drawer will not open if it is locked with the drawer key.

### Drawer lock

Use the drawer key to lock and unlock the drawer.

### Multipurpose tray

This tray can always be opened if the locking knob is in the unlock position.

Use the locking knob to lock and unlock this tray.

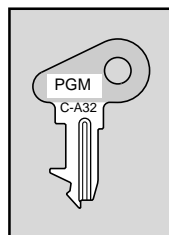

**Program key**

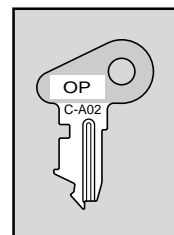

**Operator key**

# Introducing TE-2000

## Mode switch

Use the mode keys to change the position of the mode switch and select the mode you want to use.

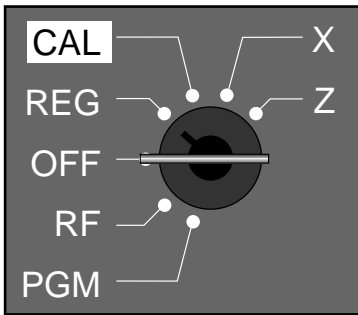

Mode Switch	Mode Name	Description
Z	RESET	Reads sales data in memory and clears the data.
X	READ	Reads sales data in memory without clearing the data.
CAL	CALCULATOR	Use this mode for calculator.
REG	REGISTER	Use this mode for normal registration.
OFF	STAND-BY	Cash register standing by.
RF	REFUND	Use this mode to register refund transaction.
PGM	PROGRAM	Use this mode for cash register programming.

## Lock/unlock the multipurpose tray

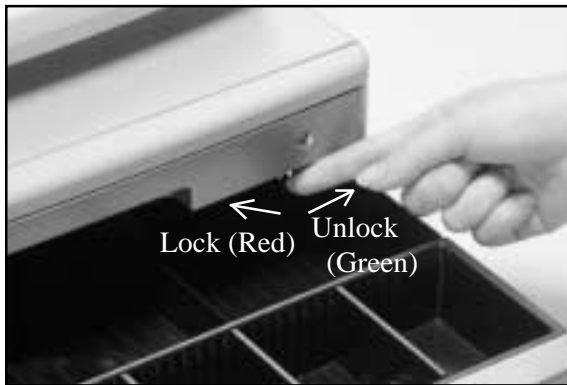

### When the cash drawer does not open!

In case of power failure or the machine is in malfunction, the cash drawer does not open automatically. Even in these cases, you can open the cash drawer by pulling drawer release lever (see below).

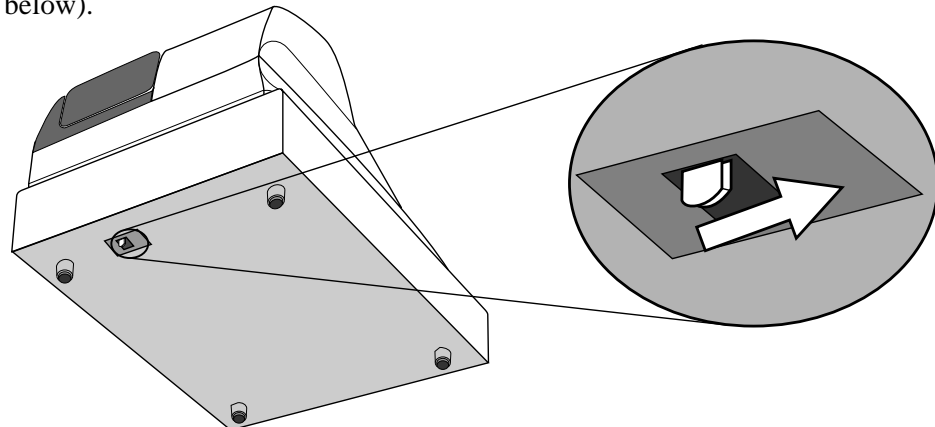

### Important!

The drawer will not open, if it is locked with a drawer lock key.

## Displays

### Main Display

(alphanumeric + numeric display)

### Pop-up (customer) display

(numeric display)

#### Item registration (by department/PLU)

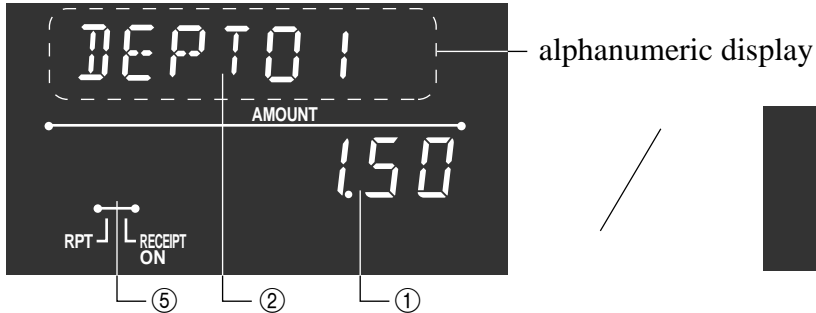

#### Repeat registration

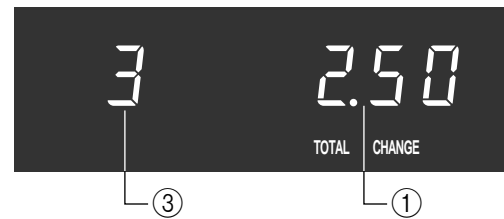
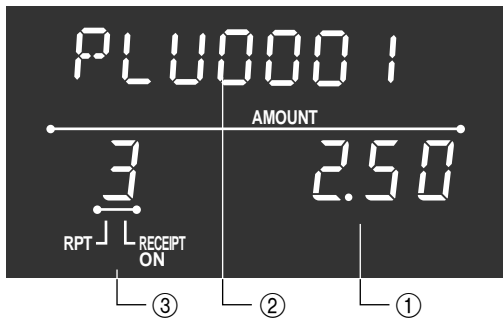

#### Totalize operation

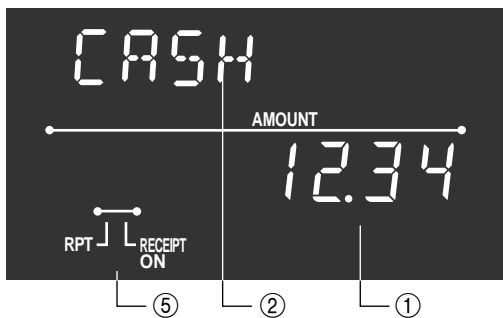

#### ① Amount/Quantity

This part of the display shows monetary amounts. It also can be used to show the current time. (The current date is shown in the alphanumeric display.)

#### ② Item/Key descriptor

When you register an item or key, the item/key descriptor appears here. Mode descriptor is also displayed here.

#### ③ Number of repeats

Anytime you perform a repeat registration (page 25, 29), the number of repeats appears here.

Note that only one digit is displayed for the number of repeats. This means that a “5” could mean 5, 15 or even 25 repeats.

#### ④ Total/Change indicators

When the TOTAL indicator is lit, the displayed value is monetary total or subtotal amount.

When the CHANGE indicator is lit, the displayed value is the change due.







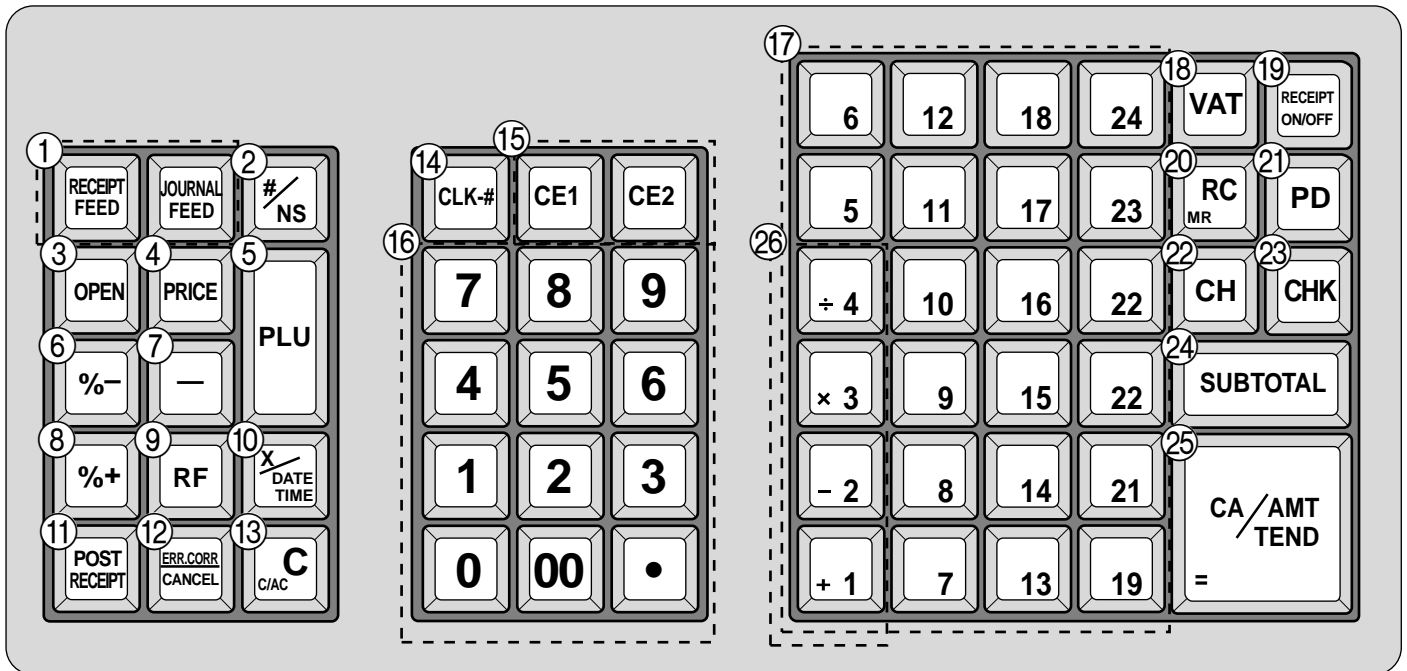

















#### ⑤ Receipt on/off indicators

When the register is in “issuing receipt” mode, under-bar sign is lit on this digit. (REG/RF mode, during standing-by only)

## Keyboard



### • Register Mode

- ① **Paper feed key**    
Hold this key down to feed paper from the printer.
- ② **Non-add/No sale key**   
Non-add key: To print reference number (to identify a personal check, credit card, etc.) during a transaction, use this key after some numerical entries.  
No sale key: Use this key to open the drawer without registering anything.
- ③ **Open key**   
Use this key to temporarily release a limitation on the number of digits that can be input for a unit price.
- ④ **Price key**   
Use this key to register unit prices for subdepartment.
- ⑤ **PLU key**   
Use this key to input PLU (subdepartment) numbers.
- ⑥ **Discount key**   
Use this key to register discounts.
- ⑦ **Minus key**   
Use this key to input values for subtraction.
- ⑧ **Premium key**   
Use this key to register premiums.
- ⑨ **Refund key**   
Use this key to input refund amounts and void certain entries.
- ⑩ **Multiplication/Date/Time key**   
Use this key to input a quantity for a multiplication operation. Between transactions, this key displays the current time and date.
- ⑪ **Post receipt key**   
Use this key to produce a post-finalization receipt (page 43).
- ⑫ **Error correct/Cancel key**   
Use this key to correct registration errors and to cancel registration of entire transactions.
- ⑬ **Clear key**   
Use this key to clear an entry that has not yet been registered.
- ⑭ **Clerk number key**  
Use this key to sign clerk on and off the register.
- ⑮ **Currency exchange key** ,   
Use this key for calculating subtotal amounts or paying amount due in foreign currency (page 62).
- ⑯ **Ten key pad** , , ~ , ,   
Use these keys to input numbers.
- ⑰ **Department keys** , , ~   
Use these keys to register items to departments.

- ⑱ **VAT key** VAT  
Use this key to print a VAT breakdown.
- ⑲ **Receipt on/off key** RECEIPT  
ON/OFF  
Use this key twice to change the status “receipt issue” or “no receipt.” In case of “receipt issue”, the “RECEIPT ON” indicator is lit.
- ⑳ **Received on account key** RC  
MR  
Use this key following a numeric entry to register money received for non-sale transactions.
- ㉑ **Paid out key** PD  
Use this key following a numeric entry to register money paid out from the drawer.
- ㉒ **Charge key** CH  
Use this key to register a charge sale.
- ㉓ **Check key** CHK  
Use this key to register a check tender.
- ㉔ **Subtotal key** SUB  
TOTAL  
Use this key to display and print the current subtotal (includes add-on tax) amount.
- ㉕ **Cash amount tendered key** CA/AMT  
=/TEND  
Use this key to register a cash sale.

## • Calculator Mode

- ② **Drawer open key** #/NS
- ⑥ **Discount key** %-
- ⑬ **Clear/All clear key** C  
CNC
- ⑯ **Ten key pad** 0, 1, ~ 9, 00, .
- ⑳ **Arithmetic operation key** + 1, - 2, × 3 and ÷ 4
- ㉑ **Memory recall key** RC  
MR
- ㉕ **Equal key** CA/AMT  
=/TEND

# Basic Operations and Setups

## How to read the printouts

- The journal and receipts are records of all transactions and operations.
- The contents printed on receipts and journal are identical, except the date/logo message/commercial message/ bottom message printing line. (They are printed on receipts and reports.)
- You can choose the journal skip function (page 44).  
If the journal skip function is selected, the cash register will print the total amount of each transaction, and the details of premium, discount and reduction operations only, without printing department and PLU item registrations on the journal.
- The following items can be skipped on receipts and journal.
  - Time
  - Consecutive number
  - Taxable status
  - Taxable amount

**Receipt Sample**

*****				
* * THANK YOU *				Logo message or graphic logo
** CALL AGAIN **				
*****				
* COMMERCIAL MESSAGE *				Commercial message
* COMMERCIAL MESSAGE *				
* COMMERCIAL MESSAGE *				
* COMMERCIAL MESSAGE *				
REG 15-03-2002 12:34				Mode/Date/Time
CLERK 01 0001-000123				Clerk/Machine No. -Consecutive No.
DEPT01 T1 .1.00				
DEPT02 T1 .2.00				
5 X @1.00				
DEPT03 T2 .5.00				
TAX-AMT 1 .3.00				Taxable amount with tax rate
TAX 1 5% .0.15				
TAX-AMT 2 .5.00				
TAX 2 4% .0.20				Tax total
TAX .0.35				
TOTAL .8.35				
CASH .10.00				
CHANGE .1.65				
7 No				Item counter
*** BOTTOM MESSAGE ***				Bottom message
*** BOTTOM MESSAGE ***				
*** BOTTOM MESSAGE ***				
*** BOTTOM MESSAGE ***				
*** BOTTOM MESSAGE ***				

**Journal Sample (Item lines Included) (normal height)**

REG		12:33	
CLERK 01		0001-000122	
DEPT01		.1.00	
DEPT02		.2.00	
TAX-AMT 1		.3.00	
TAX 1		.0.15	
TAX		.0.15	
CASH		.3.15	
7 No			
REG		12:34	
CLERK 01		0001-000123	
DEPT01 T1		.1.00	
DEPT02 T1		.2.00	
5 X @1.00			
DEPT03 T2		.5.00	
TAX-AMT 1		.3.00	
TAX 1 5%		.0.15	
TAX-AMT 2		.5.00	
TAX 2 4%		.0.20	
TAX		.0.35	
TOTAL		.8.35	
CASH		.10.00	
CHANGE		.1.65	
7 No			
REG		12:35	
CLERK 01		0001-000124	
DEPT01 T1		.1.00	
DEPT02 T1		.2.00	
5 X @1.00			
DEPT03 T2		.5.00	

**Journal Sample (Item lines Skipped) (half height)**

REG		15-03-2002 12:32	
CLERK 01		0001-000121	
TAX-AMT 1		.3.00	
TAX 1		.0.15	
TAX		.0.15	
CASH		.3.15	
2 No			
REG		15-03-2002 12:33	
CLERK 01		0001-000122	
TAX-AMT 1		.3.00	
TAX 1 5%		.0.15	
TAX		.0.15	
CASH		.3.15	
2 No			
REG		15-03-2002 12:34	
CLERK 01		0001-000123	
TAX-AMT 1		.3.00	
TAX 1 5%		.0.15	
TAX-AMT 2		.5.00	
TAX 2 4%		.0.20	
TAX		.0.35	
TOTAL		.8.35	
CASH		.10.00	
CHANGE		.1.65	
7 No			
REG		15-03-2002 12:35	
CLERK 01		0001-000124	
TAX-AMT 1		.3.00	
TAX 1 5%		.0.15	
TAX-AMT 2		.5.00	
TAX 2 4%		.0.20	
TAX		.0.35	
TOTAL		.8.35	
CASH		.10.00	
CHANGE		.1.65	

In the operation examples contained in this manual, the print samples are what would be produced if the roll paper is being used for receipts. They are not actual size. Actual receipts are 58 mm wide. Also, all sample receipts and journals are printout images.

# How to use your cash register

The following describes the general procedure you should use in order to get the most out of your cash register.

## BEFORE business hours...

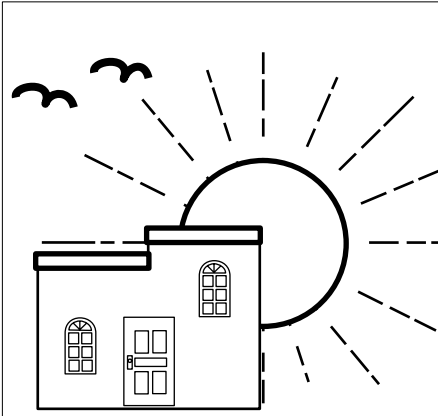

- Check to make sure that the cash register is plugged in securely. Page 11
- Check to make sure there is enough paper left on the roll. Page 9, 10
- Read the financial totals to confirm that they are all zero. Page 70
- Check the date and time. Page 24

## DURING business hours...

- Register transactions. Page 25
- Periodically read totals. Page 69



## AFTER business hours...

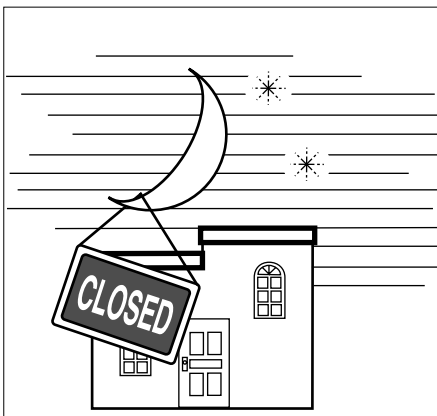

- Reset the daily totals. Page 41
- Remove the journal. Page 81
- Empty the cash drawer and leave it open. Page 18
- Take the cash and journal to the office.

# Basic Operations and Setups

## Displaying the time and date

You can show the time and date on the display of the cash register whenever there is no registration being made.

### To display and clear the time and date

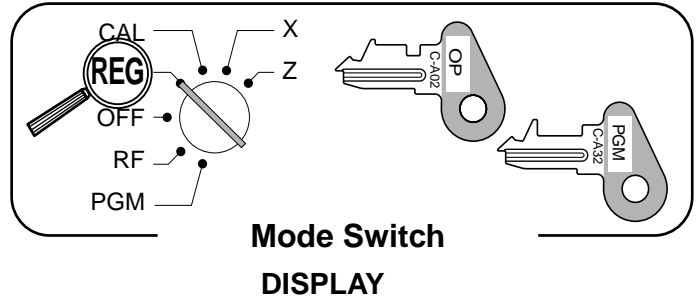

OPERATION

DISPLAY



Day Month Year

Hour Minutes.  
(24-hour system)



## Preparing coins for change

You can use the following procedure to open the drawer without registering an item. This operation must be performed out of a sale.

(You can use the key instead of the key. See page 37.)

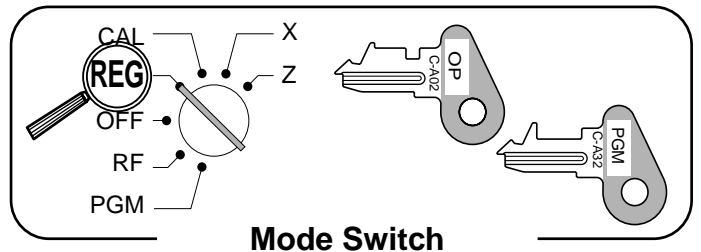

Mode Switch

### Opening the drawer without a sale

OPERATION

RECEIPT

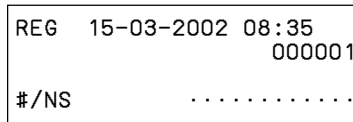

# Preparing and using department keys

## Registering department keys

The following examples show how you can use the department keys in various types of registrations.

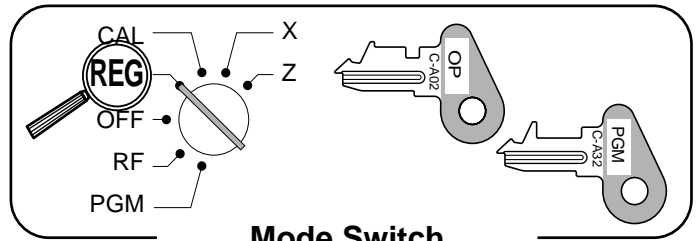

### Single item sale

#### OPERATION

Item	Unit price	\$1.00
	Quantity	1
	Dept.	1
Payment	Cash	\$1.00

**1 00**

Unit price

**+ 1**

Department

**CA/AMT  
= /TEND**

#### RECEIPT

REG	15-03-2002	08:40	Mode/date/time
		000002	Consecutive No.
DEPT01		. 1.00	Department descriptor/unit price
CASH		. 1.00	Cash total amount

### Repeat

#### OPERATION

Item	Unit price	\$1.50
	Quantity	3
	Dept.	1
Payment	Cash	\$10.00

**1 5 0 + 1**

**+ 1**

**+ 1**

**SUB  
TOTAL**

**1 0 00 CA/AMT  
= /TEND**

#### RECEIPT

REG	15-03-2002	08:45	
		000003	
DEPT01		. 1.50	Repeat
DEPT01		. 1.50	Repeat
DEPT01		. 1.50	
TOTAL		. 4.50	
CASH		. 10.00	
CHANGE		. 5.50	

### Multiplication

#### OPERATION

Item	Unit price	\$1.00
	Quantity	12.5
	Dept.	1
Payment	Cash	\$20.00

**1 2 . 5** **X DATE  
TIME**

Quantity  
(4-digit integer/2-digit decimal)

**1 00 + 1**

**SUB  
TOTAL**

**2 0 00 CA/AMT  
= /TEND**

#### RECEIPT

REG	15-03-2002	08:50	
		000004	
	12.5	X @1.00	Quantity/unit price
DEPT01		. 12.50	
TOTAL		. 12.50	
CASH		. 20.00	
CHANGE		. 7.50	

# Basic Operations and Setups

## Programming department keys

To program a unit price for each department

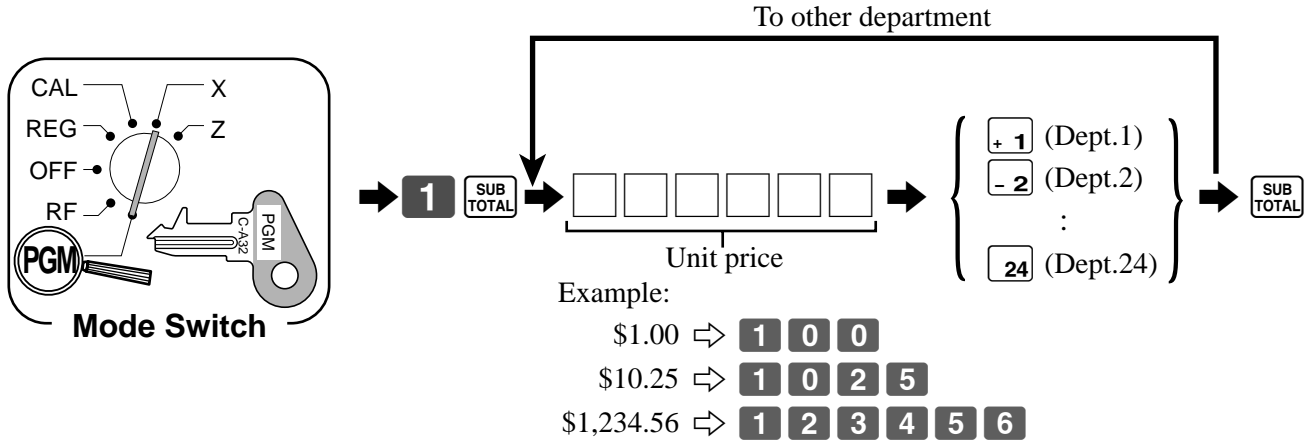

## To program the tax calculation status for each department

### Tax calculation status

This specification defines which tax table should be used for automatic tax calculation. See page 13 for information on setting up the tax tables.

### Programming procedure

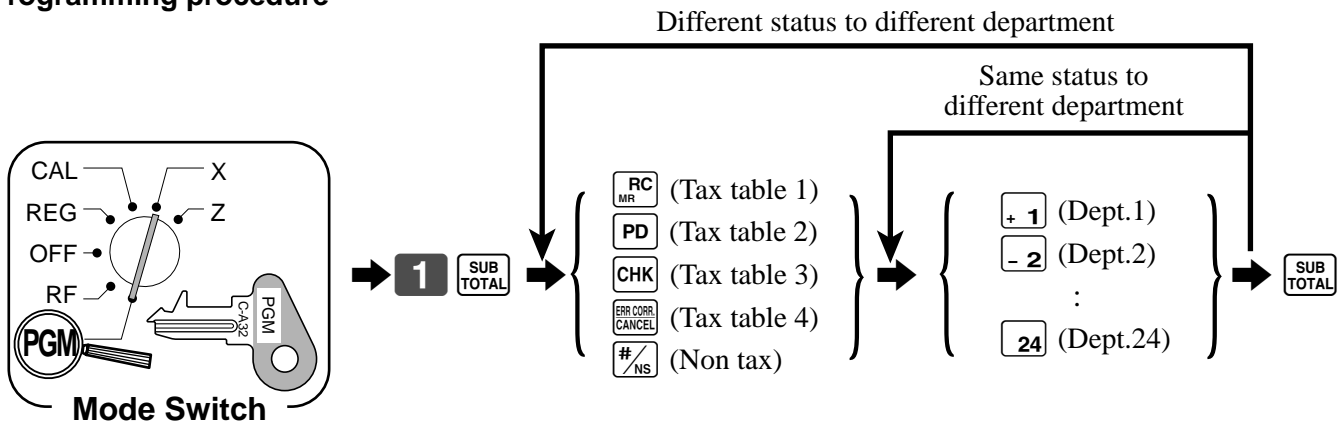

Note: Tax symbols

T1: Tax table 1

T2: Tax table 2

T3: Tax table 3

T4: Tax table 4

All departments are initialized as non-tax.

## Registering department keys by programming data

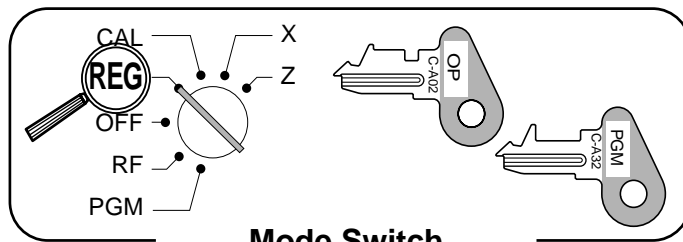

### Preset price

#### OPERATION

Item	Unit price	(\$1.00)
	Quantity	1
	Dept.	2
Payment	Cash	\$1.00

( ): Preset value

**- 2**

**CA/AMT  
=/TEND**

#### Mode Switch

#### RECEIPT

REG	15-03-2002 08:55	000005	
DEPT02		. 1.00	Department descriptor/unit price
CASH		. 1.00	

### Preset tax status (Add-on tax)

#### OPERATION

Item 1	Unit price	(\$2.00)
	Quantity	5
	Dept.	3
	Taxable	(1)
Item 2	Unit price	(\$2.00)
	Quantity	1
	Dept.	4
	Taxable	(2)
Payment	Cash	\$20.00

( ): Preset value

**5** **X/DATE TIME**  
**x 3**  
**÷ 4**  
**SUB TOTAL**  
**2 0 00** **CA/AMT =/TEND**

#### RECEIPT

REG	15-03-2002 09:00	000006	
5 X	@2.00		Tax status symbols *
DEPT03		. 10.00	
DEPT04		. 2.00	
TAX-AMT 1		. 10.00	Taxable Amount 1
TAX 1		. 0.50	Tax 1
TAX-AMT 2		. 2.00	Taxable Amount 2
TAX 2		. 0.12	Tax 2
TOTAL		. 12.62	
CASH		. 20.00	
CHANGE		. 7.38	

\* To print tax status symbols, please refer to page 44.

### Preset tax status (Add-in tax)

#### OPERATION

Item 1	Unit price	(\$2.00)
	Quantity	5
	Dept.	3
	Taxable	(1)
Item 2	Unit price	(\$2.00)
	Quantity	1
	Dept.	4
	Taxable	(2)
Payment	Cash	\$20.00

( ): Preset value

**5** **X/DATE TIME**  
**x 3**  
**÷ 4**  
**SUB TOTAL**  
**2 0 00** **CA/AMT =/TEND**

#### RECEIPT

REG	15-03-2002 09:05	000007	
5 X	@2.00		Tax status symbols *
DEPT03		. 10.00	
DEPT04		. 2.00	
TOTAL		. 12.00	
CASH		. 20.00	
CHANGE		. 8.00	

\* To print tax status symbols, please refer to page 44.

## Preparing and using PLUs

This section describes how to prepare and use PLUs.

### CAUTION:

Before you use PLUs, you should first tell the cash register how it should handle the registration.

### Programming PLUs

#### To program a unit price for each PLU

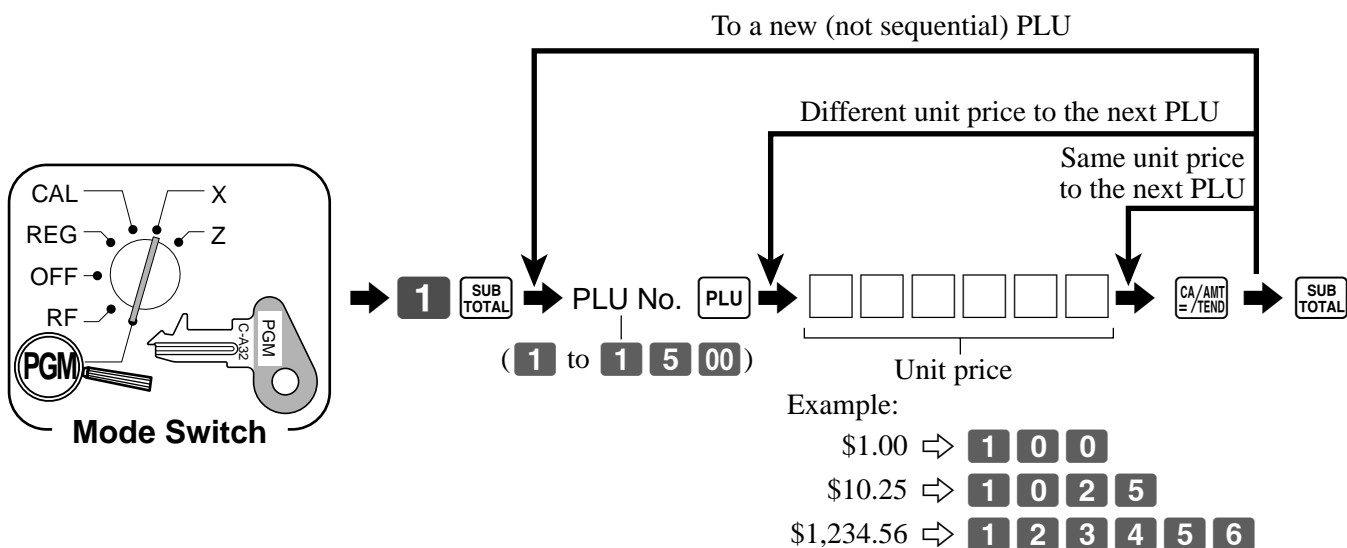

#### To program tax calculation status for each PLU

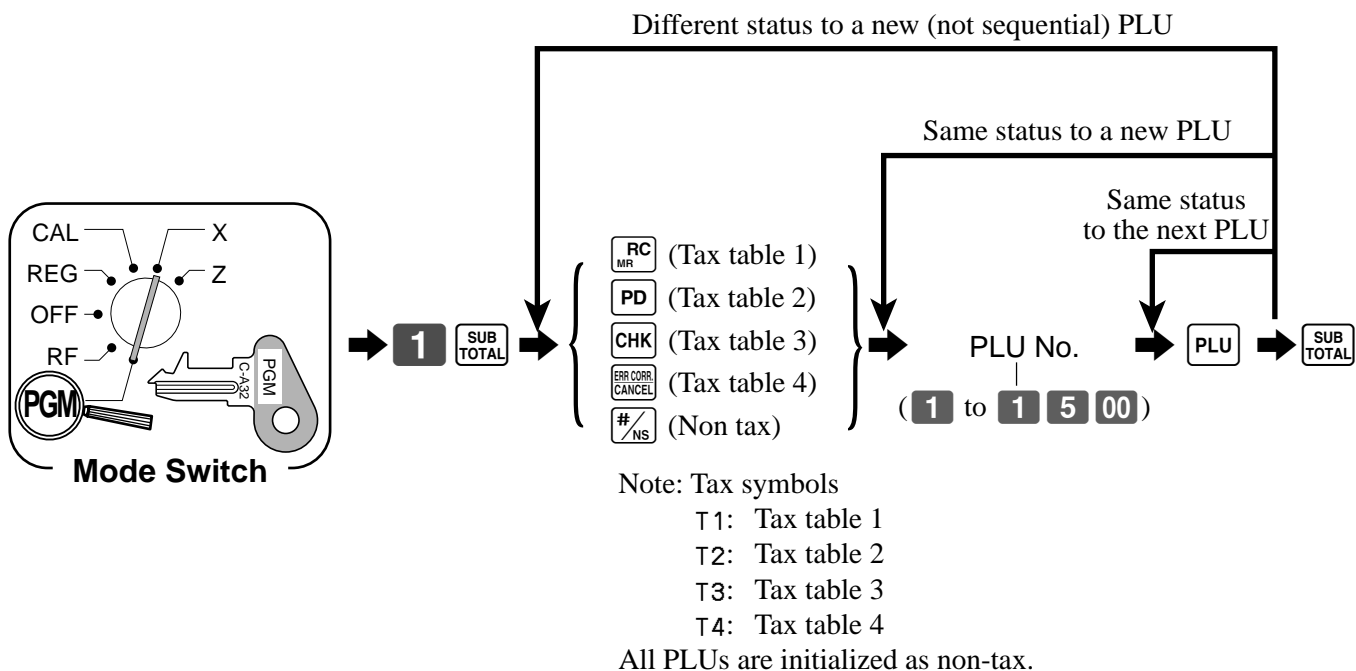

## Registering PLUs

The following examples show how you can use PLUs in various types of registrations.

Registering by subdepartment, see the “Convenient Operations and Setups” on page 60.

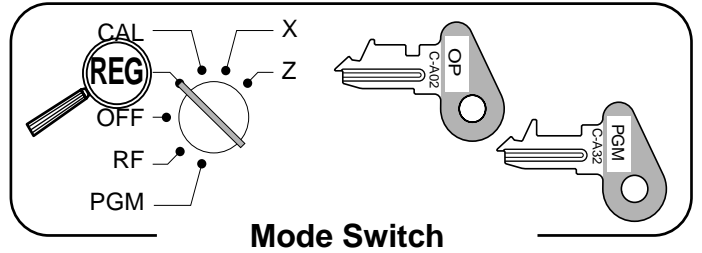

Mode Switch

### PLU single item sale

Item	Unit price	(\$2.50)
	Quantity	1
	PLU	14
Payment	Cash	\$3.00

( ): Preset value

#### OPERATION

**1 4**  
PLU code

**PLU**

**SUB**

**3 00** **CA/AMT =/TEND**

#### RECEIPT

REG	15-03-2002 09:10	000008	
PLU0014		.2.50	PLU descriptor/ unit price
TOTAL		.2.50	
CASH		.3.00	
CHANGE		.0.50	

### PLU repeat

Item	Unit price	(\$2.50)
	Quantity	3
	PLU	14
Payment	Cash	\$10.00

( ): Preset value

#### OPERATION

**1 4** **PLU**

**PLU**

**PLU**

**SUB**

**1 0 00** **CA/AMT =/TEND**

#### RECEIPT

REG	15-03-2002 09:15	000009	
PLU0014		.2.50	
PLU0014		.2.50	
PLU0014		.2.50	
TOTAL		.7.50	
CASH		.10.00	
CHANGE		.2.50	

### PLU multiplication

Item	Unit price	(\$1.20)
	Quantity	15
	PLU	2
Payment	Cash	\$20.00

( ): Preset value

#### OPERATION

**1 5** **X DATE TIME**  
Quantity  
(4-digit integer/2-digit decimal)

**2** **PLU**

**SUB**

**2 0 00** **CA/AMT =/TEND**

#### RECEIPT

REG	15-03-2002 09:20	000010	
15 X	@1.20		
PLU0002		.18.00	
TOTAL		.18.00	
CASH		.20.00	
CHANGE		.2.00	

## Preparing and using discounts/premiums

This section describes how to prepare and register discount and premium.

### Programming discounts/premiums

You can use the **%-** key to register discounts (percentage decreases) and the **%+** key to register premium (percent increases).

#### To program a rate to the **%-** key and **%+** key

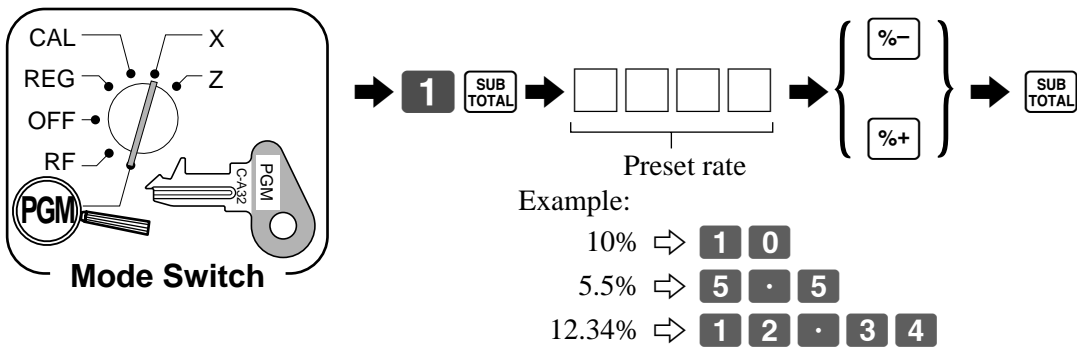

#### To program tax status to the **%-** key and **%+** key

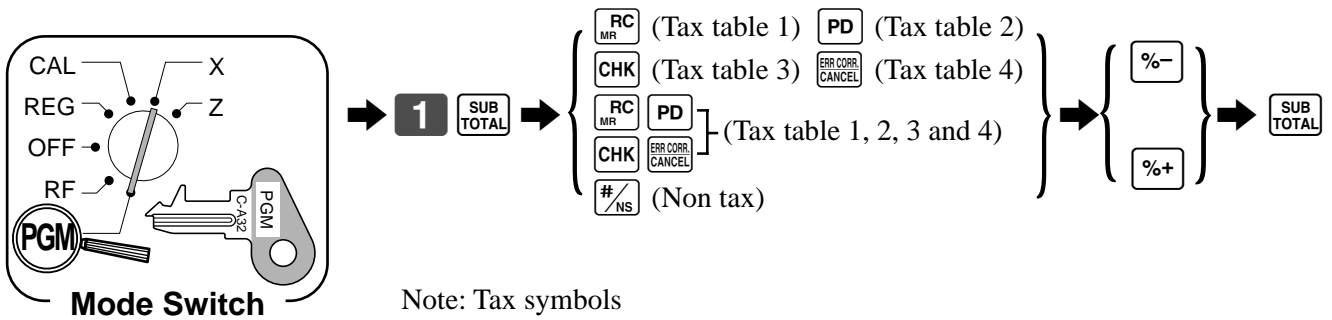

Note: Tax symbols

T1: Tax table 1

T2: Tax table 2

T3: Tax table 3

T4: Tax table 4

\*: Tax table 1, 2, 3 and 4

**%-** and **%+** are initialized as non-tax.

## Registering discounts/premiums

The following example shows how you can use the **%-**/**%+** key in various types of registration.

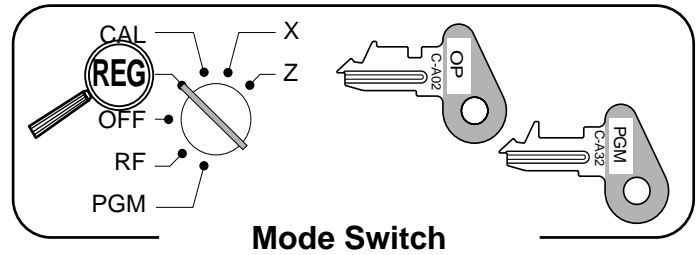

### Discount for items and subtotals

#### OPERATION

#### RECEIPT

Item 1	Unit price	\$5.00
	Quantity	1
	Dept.	1
Item 2	Unit price	(\$10.00)
	Quantity	1
	PLU	16
Discount	Rate	(5%)
Subtotal	Rate	3.5%
Discount	Rate	3.5%
Payment	Cash	\$15.00

( ): Preset value

5 00 + 1  
1 6 PLU  
%  
Applies the preset discount rate to the last item registered.

3 . 5 %  
SUB TOTAL

The input value takes priority of the preset value.

1 5 00 CA/AMT =/TEND

```
REG 15-03-2002 10:30
                                000013
DEPT01                          .5.00
PLU0016                          .10.00
  5%
%-                               -0.50
ST                               -14.50
  3.5%
%-                               -0.51
TOTAL                            .13.99
CASH                             .15.00
CHANGE                            .1.01
```

### Premium for items and subtotals

#### OPERATION

#### RECEIPT

Item 1	Unit price	(\$10.00)
	Quantity	1
	Dept.	4
Premium	Rate	7%
Item 2	Unit price	(\$5.00)
	Quantity	1
	PLU	32
Subtotal	Rate	(5%)
Payment	Cash	\$20.00

( ): Preset value

± 4  
7 %+  
Applies the input value as a premium rate (7%).

3 2 PLU  
SUB TOTAL  
%+

Applies the preset premium rate (5%) to the subtotal.

2 0 00 CA/AMT =/TEND

```
REG 15-03-2002 13:15
                                000037
DEPT04                          .10.00
  7%
%+                               .0.70
PLU0032                          .5.00
ST                               -15.70
  5%
%+                               .0.79
TOTAL                            .16.49
CASH                             .20.00
CHANGE                            .3.51
```

- You can manually input rates up to 4 digits long (0.01% to 99.99%).



### Taxable status of the **%-** and **%+** key

- Whenever you perform a discount/premium operation on the last item registered, the tax calculation for discount/premium amount is performed in accordance with the tax status programmed for that item.
- Whenever you perform a discount/premium operation on a subtotal amount, the tax calculation for the subtotal amount is performed in accordance with the tax status programmed for the **%-** or **%+** key.

## Preparing and using reductions

This section describes how to prepare and register reductions.

### Programming for reductions

You can use the  key to reduce single item or subtotal amounts. The following procedure lets you program the tax calculation method for the  key.

### To program tax calculation status

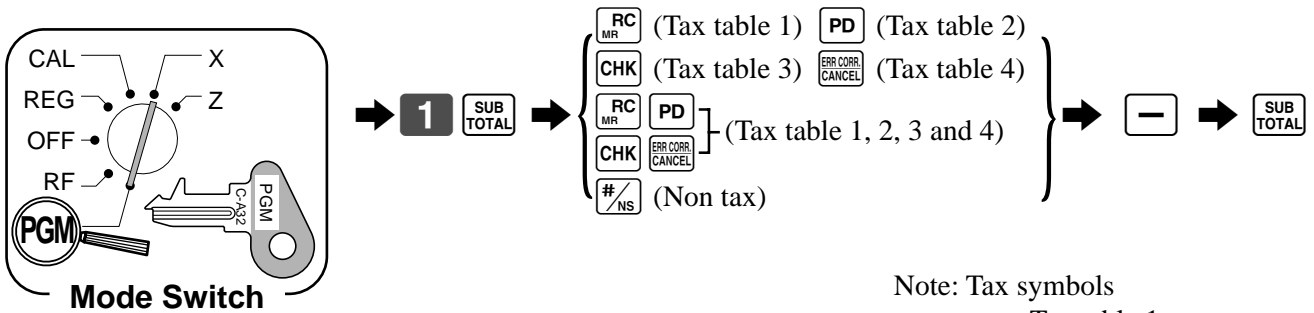

Note: Tax symbols

T1: Tax table 1

T2: Tax table 2

T3: Tax table 3

T4: Tax table 4

\*: Tax table 1, 2, 3 and 4

 is initialized as non-tax.

### Taxable status of the key

The tax calculation for the reduction amount is performed in accordance with the tax status programmed for the  key, regardless of whether the reduction is performed on the last item registered or a subtotal amount.

### To program preset reduction amount

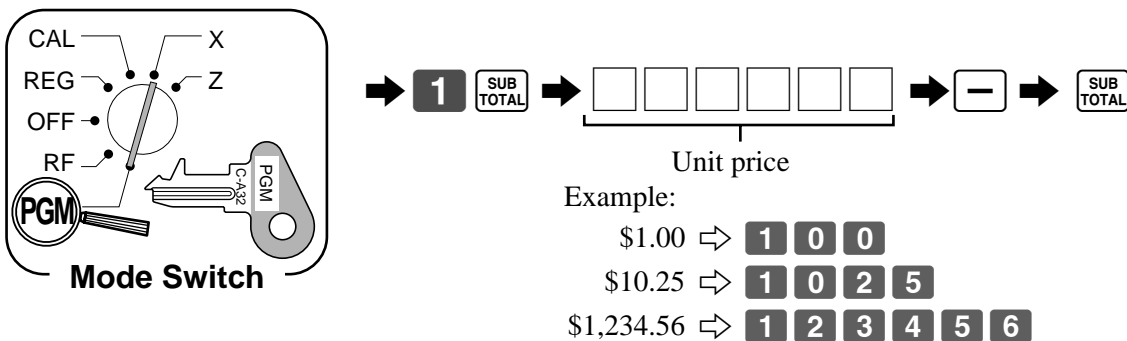

## Registering reductions

The following examples show how you can use the  key in various types of registration.

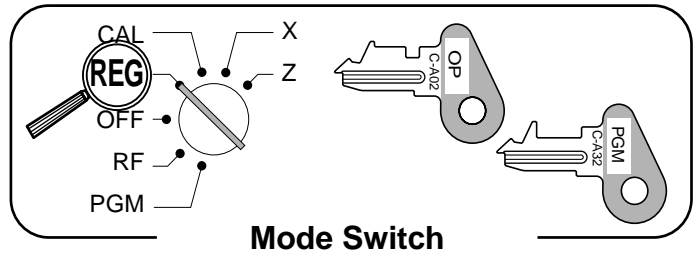







### Reduction for items

#### OPERATION

#### RECEIPT

Item 1	Unit price	\$5.00
	Quantity	1
	Dept.	1
Reduction	Amount	\$0.25
Item 2	Unit price	(\$6.00)
	Quantity	1
	PLU	45
Reduction	Amount	(\$0.50)
Payment	Cash	\$11.00

( ): Preset value

  
  
 Reduces the last amount registered by the value input.  
  
  
  

```

REG 15-03-2002 10:35
                                000014

DEPT01                          .5.00
-                                -0.25
PLU0045                          .6.00
-                                -0.50
TOTAL                            .10.25
CASH                             .11.00
CHANGE                           .0.75
    
```







- You can manually input reduction values up to 7 digits long.
- The amount you input for the reduction is neither subtracted from the department nor PLU totalizer.

### Reduction for subtotal

#### OPERATION

#### RECEIPT

Item 1	Unit price	\$3.00
	Quantity	1
	Dept.	1
Item 2	Unit price	\$4.00
	Quantity	1
	Dept.	2
Subtotal Reduction	Amount	\$0.75
Payment	Cash	\$7.00

  
  
  
  
 Reduces the subtotal by the value input here.  
  

```

REG 15-03-2002 10:40
                                000015

DEPT01                          .3.00
DEPT02                          .4.00
-                                -0.75
TOTAL                            .6.25
CASH                             .7.00
CHANGE                           .0.75
    
```

# Basic Operations and Setups

## Registering charge and check payments

The following examples show how to register charges and payments by check.

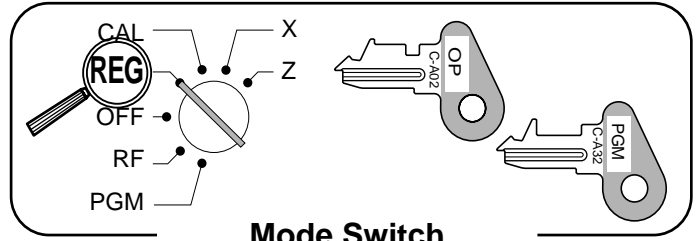

### Check

#### OPERATION

#### RECEIPT

Item	Unit price	\$10.00
	Quantity	1
	Dept.	1
Payment	Check	\$10.00

1 0 00 + 1  
SUB TOTAL  
1 0 00 CHK

```
REG 15-03-2002 10:50
      000018
DEPT01          .10.00
TOTAL          .10.00
CHECK          .10.00
CHANGE         .00.00
```

### Charge

#### OPERATION

#### RECEIPT

Item	Unit price	\$15.00
	Quantity	1
	Dept.	4
Reference	Number	0123
Payment	Charge	\$15.00

1 5 00 ± 4  
SUB TOTAL  
0 1 2 3 #/NS  
CH

```
REG 15-03-2002 10:55
      000019
DEPT04          .15.00
#/NS           0123 Reference No.
CHARGE         .15.00
```

### Mixed tender (cash, charge and check)

#### OPERATION

#### RECEIPT

Item	Unit price	\$55.00
	Quantity	1
	Dept.	4
Payment	Check	\$30.00
	Cash	\$5.00
	Charge	\$20.00

5 5 00 ± 4  
SUB TOTAL  
3 0 00 CHK  
5 00 CA/AMT =/TEND  
CH

```
REG 15-03-2002 11:00
      000020
DEPT04          .55.00
TOTAL          .55.00
CHECK          .30.00
CASH           .5.00
CHARGE         .20.00
```

# Registering returned goods in the REG mode

The following example shows how to use the **RF** key in the REG mode to register goods returned by customers.

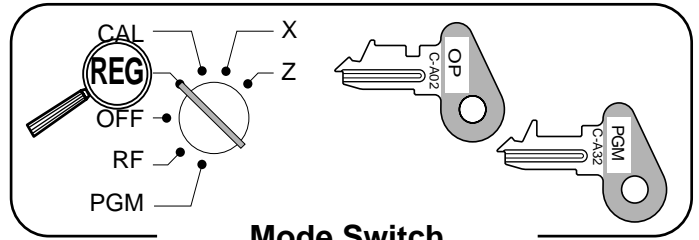

**Mode Switch**

## OPERATION

Item 1	Unit price	\$2.35
	Quantity	1
	Dept.	1
Item 2	Unit price	\$2.00
	Quantity	1
	Dept.	2
Item 3	Unit price	(\$1.20)
	Quantity	1
	PLU	1
Item 1 Returned	Unit price	\$2.35
	Quantity	1
	Dept.	1
Item 3 Returned	Unit price	(\$1.20)
	Quantity	1
	PLU	1
Payment	Cash	\$2.00

( ): Preset value

**2 3 5 + 1**

**2 00 - 2**

**1 PLU**

**RF**

**2 3 5 + 1**

Pressing **RF** specifies that the next item registered is a return.

**RF**

**1 PLU**

You have to press **RF** before registering each returned item.

**SUB  
TOTAL**

**CA/AMT  
=/TEND**

## RECEIPT

```

REG 15-03-2002 11:05
                                000021
DEPT01                          .2.35
DEPT02                          .2.00
PLU0001                          .1.20
REFUND .....
DEPT01                          -2.35
REFUND .....
PLU0001                          -1.20
CASH                             .2.00
    
```

## Registering returned goods in the RF mode

The following examples show how to use the RF mode to register goods returned by customers.

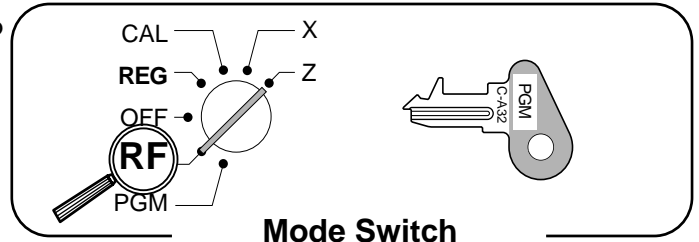

### Normal refund transaction

#### OPERATION

Item 1 Returned	Unit price	\$1.50
	Quantity	2
	Dept.	1
Item 2 Returned	Unit price	(\$1.20)
	Quantity	6
	PLU	2
Payment	Cash	\$10.20

( ): Preset value

1 5 0 + 1  
+ 1  
6 X/DATE TIME  
2 PLU  
SUB TOTAL  
CA/AMT = /TEND

#### RECEIPT

RF mode symbol

RF	15-03-2002	11:10	000022
DEPT01			. 1.50
DEPT01			. 1.50
PLU0002	6 X	@1.20	. 7.20
CASH			. 10.20

### Reduction of amounts paid on refund

#### OPERATION

Item 1 Returned	Unit price	\$4.00
	Quantity	1
	Dept.	3
Reduction	Amount	\$0.15
Item 2 Returned	Unit price	(\$1.20)
	Quantity	1
	PLU	2
Discount	Rate	(5%)
Payment	Cash	\$4.99

( ): Preset value

4 00 x 3  
1 5 -  
2 PLU  
%-  
SUB TOTAL  
CA/AMT = /TEND

#### RECEIPT

RF mode symbol

RF	15-03-2002	11:15	000023
DEPT03			. 4.00
-			-0.15
PLU0002	5%		. 1.20
%-			-0.06
CASH			. 4.99

### Important!

To avoid miss registrations in the RF mode, return the mode switch to the former position immediately.

## Registering money received on account

The following example shows how to register money received on account. This registration must be performed out of a sale.

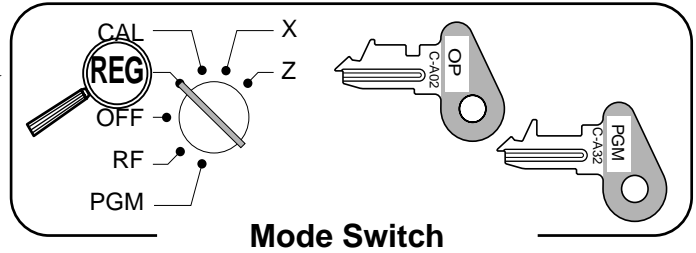

### OPERATION

Received amount	\$700.00
-----------------	----------

**7 00 00** **RC**  
MR

Amount can be up to 8 digits.

### RECEIPT

REG	15-03-2002	11:20
		000024
RC		·700.00

## Registering money paid out

The following example shows how to register money paid out from the register. This registration must be performed out of a sale.

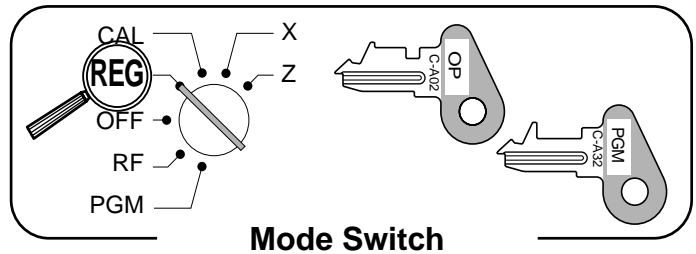

### OPERATION

Paid out amount	\$1.50
-----------------	--------

**1 5 0** **PD**

Amount can be up to 8 digits.

### RECEIPT

REG	15-03-2002	11:30
		000025
PD		·1.50

## Making corrections in a registration

There are three techniques you can use to make corrections in a registration.

- To correct an item that you input but not yet registered.
- To correct the last item you input and registered.
- To cancel all items in a transaction.

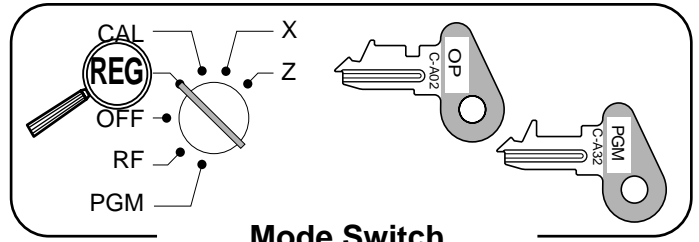

Mode Switch

### To correct an item you input but not yet registered

#### OPERATION

#### RECEIPT

<p>2 00</p> <p>1 00 <span>C</span> + 1</p> <p>1 2 <span>X/DATE TIME</span></p> <p>1 1 <span>X/DATE TIME</span></p> <p>2 00 <span>- 2</span></p> <p>2</p> <p>3 <span>C</span> <span>PLU</span></p> <p>1 5 <span>PLU</span></p> <p>6 00</p> <p>1 5 <span>C</span> <span>PLU</span></p> <p>Enter subdepartment No. again.</p> <p>1 0 00 <span>PRICE</span></p> <p><span>SUB TOTAL</span></p> <p>1 0 00</p> <p>1 5 00 <span>C</span> <span>CA/AMT = /TEND</span></p> <p><span>CH</span></p>	<p>Correction of unit price</p> <p>Correction of quantity</p> <p>Correction of PLU No.</p> <p>Correction of subdepartment unit price (See page 60 for registering.)</p> <p>Correction of partial tender amount</p>
---	--

REG	15-03-2002	11:35	
			000026
DEPT01			. 1. 00
11	X	@2.00	
DEPT02			.22. 00
PLU0003			. 1. 30
PLU0015			.10. 00
TOTAL			.34.30
CASH			.15. 00
CHARGE			.19. 30

To correct the last item you input and registered

OPERATION

RECEIPT

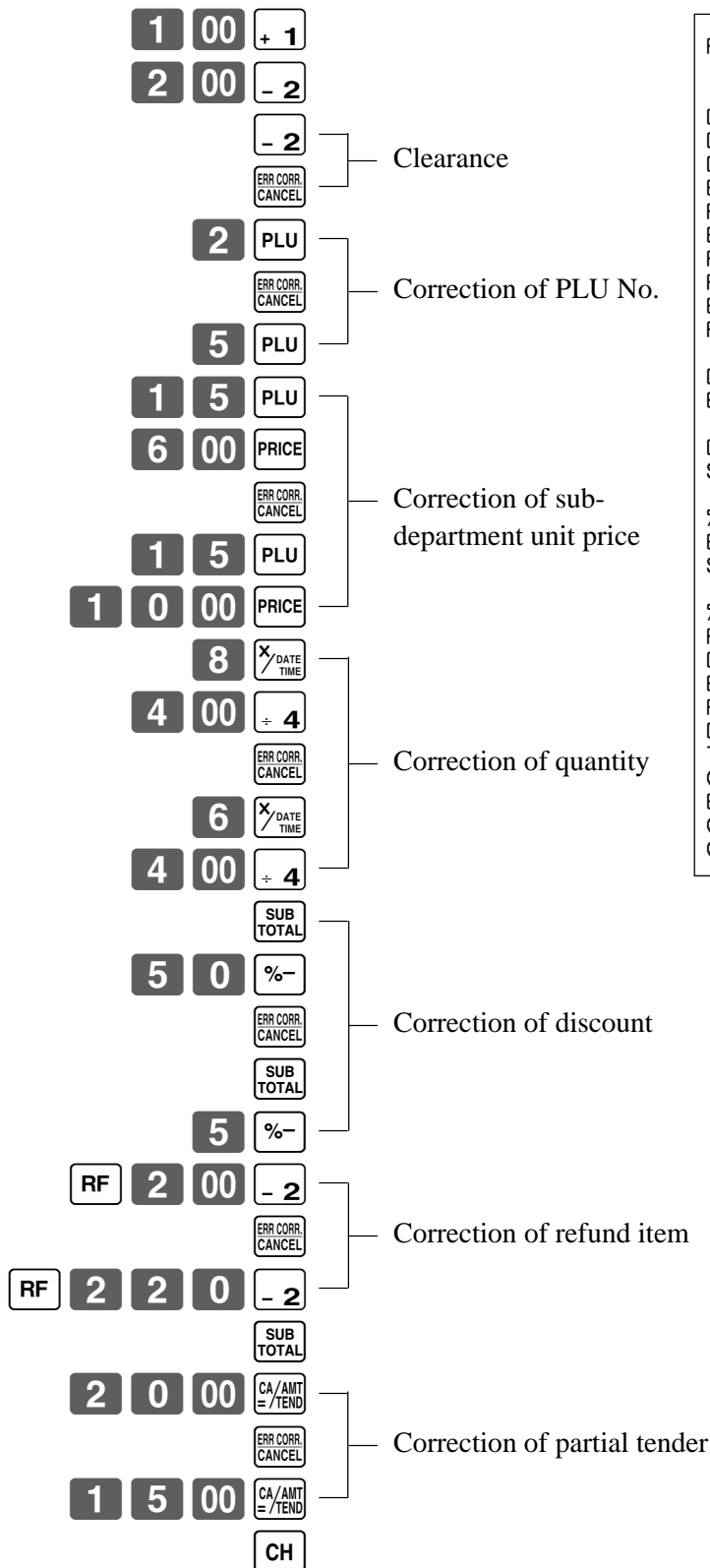

REG	15-03-2002	11:40	
			000027
DEPT01			·1.00
DEPT02			·2.00
DEPT02			·2.00
ERR CORR			·2.00
PLU0002			·1.20
ERR CORR			·1.20
PLU0005			·1.50
PLU0015			·6.00
ERR CORR			·6.00
PLU0015			·10.00
8	X	@4.00	
DEPT04			·32.00
ERR CORR			·32.00
6	X	@4.00	
DEPT04			·24.00
ST			·38.50
		50%	
%-			·19.25
ERR CORR			·19.25
ST			·38.50
		5%	
%-			·1.93
REFUND		.....	
DEPT02			·2.00
ERR CORR			·2.00
REFUND		.....	
DEPT02			·2.20
TOTAL			·34.37
CASH			·20.00
ERR CORR			·20.00
CASH			·15.00
CHARGE			·19.37

# Basic Operations and Setups

## To cancel all items in a transaction

OPERATION	RECEIPT
<p> <span>1</span> <span>00</span> <span>+ 1</span>  <span>2</span> <span>00</span> <span>- 2</span>  <span>3</span> <span>00</span> <span>× 3</span>  <span>4</span> <span>00</span> <span>± 4</span>  <span>SUB TOTAL</span> </p> <p>Pressing <span>SUB TOTAL</span> key is necessary to cancel the transaction.</p> <p><span>ERR CORR. CANCEL</span></p>	<pre> REG 15-03-2002 11:45                                 000028  DEPT01                · 1.00 DEPT02                · 2.00 DEPT03                · 3.00 DEPT04                · 4.00 CANCEL TTL  .....                     </pre>

### Important!

- Note that the number of items included in the transaction to be cancelled is limited (24 ~ 40 items), depending on the complexity of the transaction. If you try to cancel a transaction that exceeds the limit, an error occurs.  
In case of occurrence of this error, register these items in the RF mode.
- You can program the cash register that this cancel operation is not allowed.

## No sale registration

You can use the following procedure to open the drawer without registering a sale. This operation must be performed out of a sale.

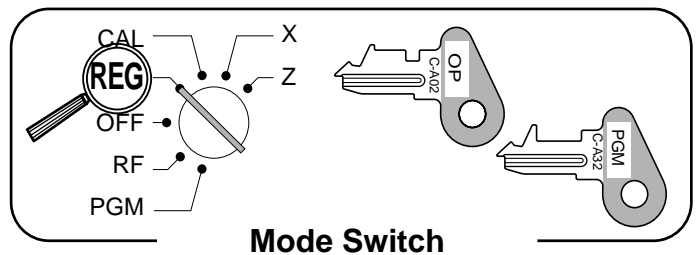

OPERATION	RECEIPT
<p><span>#/NS</span></p>	<pre> REG 15-03-2002 11:50                                 000029  #/NS  .....                     </pre>

# Printing the daily sales reset report

This report shows daily sales totals.

## OPERATION

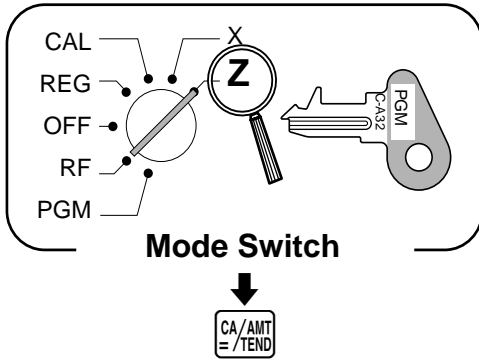

## REPORT

Z	15-03-2002	12:00		Reset mode/date/time
			000030	Consecutive No.
0000	<b>DAILY</b>	Z	0001	Report code/report title/reset symbol/ reset counter
DEPT01	QT	15		Department descriptor/No. of items* <sup>1</sup>
			·339.50	Department amount* <sup>1</sup>
DEPT02	QT	19		
			·62.70	
DEPT03	QT	31		
			·130.00	
NON-LINK DPT	QT	10		Non-link department No. of items
			·94.90	Non-link department amount
-----				
GROSS TOTAL	QT	253		Gross No. of items
			·1146.90	Gross sales amount
NET TOTAL	No	100		No. of customers
			·1217.63	Net sales amount
CASH-INDW			·903.06	Cash in drawer amount
CHARGE-INDW			·197.17	Charge in drawer amount
CHECK-INDW			·183.60	Check in drawer amount
TAX-AMT 1			·732.56	Taxable amount 1 * <sup>2</sup>
TAX 1			·43.96	Tax amount 1 * <sup>2</sup>
TAX-AMT 2			·409.72	Taxable amount 2 * <sup>2</sup>
TAX 2			·21.55	Tax amount 2 * <sup>2</sup>
TAX-AMT 3			·272.50	Taxable amount 3 * <sup>2</sup>
TAX 3			·8.18	Tax amount 3 * <sup>2</sup>
ROUNDING AMT			·4.75	Rounding amount (Australia only)
CANCEL TTL	No	2		Cancellation count
			·108.52	Cancellation amount
RF-MODE TTL	No	2		Refund mode operation count * <sup>3</sup>
			·3.74	Refund mode operation amount * <sup>3</sup>
-----				
CASH	No	81		Cash sales count
			·836.86	Cash sales amount
CHARGE	No	10		Charge sales count
			·197.17	Charge sales amount
CHECK	No	9		Check sales count
			·183.60	Check sales amount
RC	No	2		Received on Account count
			·78.00	Received on Account amount
PD	No	1		Paid out count
			·6.80	Paid out amount
-	No	8		Subtraction count
			·3.00	Subtraction amount
%-	No	10		Discount count
			·4.62	Discount amount
%+	No	1		Premium count
			·1.00	Premium amount
REFUND	No	7		Refund key count * <sup>3</sup>
			·27.79	Refund key amount * <sup>3</sup>
ERR CORR	No	10		Error correction count
			·12.76	Error correction amount
#/NS	No	5		No sale count
-----				
GRND TTL		·000000	1217.63	Non-resettable grand-sales total * <sup>3</sup>

\*<sup>1</sup> Zero totalled departments (the amount and item numbers are both zero) are not printed.

\*<sup>2</sup> Taxable amount and tax amount are printed only if the corresponding tax table is programmed.

\*<sup>3</sup> These items can be skipped by programming.

# Convenient Operations and Setups

This section describes more sophisticated setups and operations that you can use to suit the needs of your retail environment.

## Clerk control function

Clerk name printing on receipt/journal, and sales amounts summing by clerk.  
To use clerk function, refer to page 45.

### Clerk sign on and sign off

Any time you begin any registration or program, clerk sign on operation is necessary.



#### Clerk sign on

	OPERATION	RECEIPT
Signing clerk 1 on:	<b>1</b> → <input type="text" value="CLK-#"/>	<div style="border: 1px solid black; padding: 5px; display: inline-block;"><p>REG 15-03-2002 08:35 CLERK 01 000001 <small>Clerk name/consecutive No.</small> DEPT01 .1.00 DEPT02 .2.00 DEPT03 .5.00</p></div>
Signing clerk 2 on:	<b>2</b> → <input type="text" value="CLK-#"/>	
...	...	
Signing clerk 15 on:	<b>1 5</b> → <input type="text" value="CLK-#"/>	

#### Clerk sign off

	OPERATION
Signing clerk off:	<b>0</b> → <input type="text" value="CLK-#"/>

- The current clerk is also signed off whenever you set the mode switch to OFF position.

### Important!

- The error code "E08" appears on the display whenever you try to perform a registration, a read/reset operation without signing on.
- The signed on clerk is also identified on the receipt/journal.
- The clerk numbers are initialized as 1 through 15. In case of using other clerk number, see page 47 for programming.

# Post-finalization receipt format, General printing control, Compulsory, Machine features

## About post-finalization receipt

The post-finalization receipt lets you issue a receipt after finalization of the transaction. Note that all of the following conditions must be satisfied.

- The receipt issuance status must be OFF.
- The transaction must be finalized in the REG or RF mode using the ,  or  key.

## Post-finalization receipt example



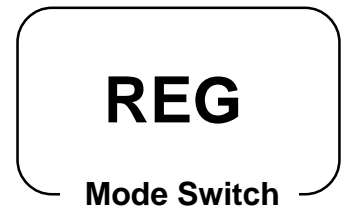

You can program the cash register to print the transaction total only (below Total format) or full details (below Detailed format) on the post-finalization receipt. Note that if the transaction contains more than 45 lines (including receipt header), the cash register prints in a Total format regardless of your programming.



### OPERATION

### RECEIPT

Item 1	Unit price	\$10.00
	Quantity	1
	Dept.	1
Item 2	Unit price	\$20.00
	Quantity	1
	Dept.	2
Payment	Cash	\$30.00

Receipt is not issued.

Post-finalization receipt is issued.

If “Automatic issue” is selected, no need to press  key.

#### Total format

```
REG 15-03-2002 12:35
CLERK 01          000123

CASH              ·30.00
```

#### Detailed format

```
REG 15-03-2002 12:35
CLERK 01          000123

DEPT01           ·10.00
DEPT02           ·20.00
TOTAL            ·30.00
CASH              ·30.00
CHARGE           ·0.00
```

### Important!

- You can issue only one post-finalization receipt per transaction.

# Convenient Operations and Setups

## Programming general printing control

Suppress printing of the subtotal line during tender operation.	a	No = 0 Yes = 1	a+b+c = <input type="text"/> D <sub>8</sub>
Print the total line even if no tender operation is made.	b	No = 0 Yes = 2	
Print tax total. (only for Australia)	c	No = 0 Yes = 4	
Print the current time.	a	Yes = 0 No = 1	a+b+c = <input type="text"/> D <sub>7</sub>
Skip the date on journal.	b	Yes = 0 No = 2	
Skip the consecutive number.	c	No = 0 Yes = 4	
Issue post receipt by Finalize key (automatic issue)/ Post receipt key (manual issue)	a	Manual = 0 Automatic = 2	a+b = <input type="text"/> D <sub>6</sub>
Detail format/Total format in the post receipt	b	Detail = 0 Total = 4	
Print taxable amount.	a	Yes = 0 No = 1	a+b+c = <input type="text"/> D <sub>5</sub>
Print tax symbols.	b	Yes = 0 No = 2	
Print number of item sold.	c	No = 0 Yes = 4	
Skip item lines on journal. (journal skip)	a	No = 0 Yes = 1	a+b+c = <input type="text"/> D <sub>4</sub>
Print subtotal when the key is pressed.	b	No = 0 Yes = 2	
Time system: ① 24 hour system, ② 12 hour system	c	① = 0 ② = 4	
Digit separator symbol.	a	Comma = 0 Period = 1	a+b+c = <input type="text"/> D <sub>3</sub>
Decimal symbol.	b	Period = 0 Comma = 2	
Journal compressed print (print by half height characters)	c	Yes = 0 No = 4	
Print hyphens before finalizing a transaction. (receipt only)	a	No = 0 Yes = 1	a+b = <input type="text"/> D <sub>2</sub>
Print tax total on receipt and report.	b	No = 0 Yes = 2	
Print Australian GST MOF message.	a	No = 0 Yes = 1	a+b = <input type="text"/> D <sub>1</sub>
Print receipt by double height characters.	b	No = 0 Yes = 2	

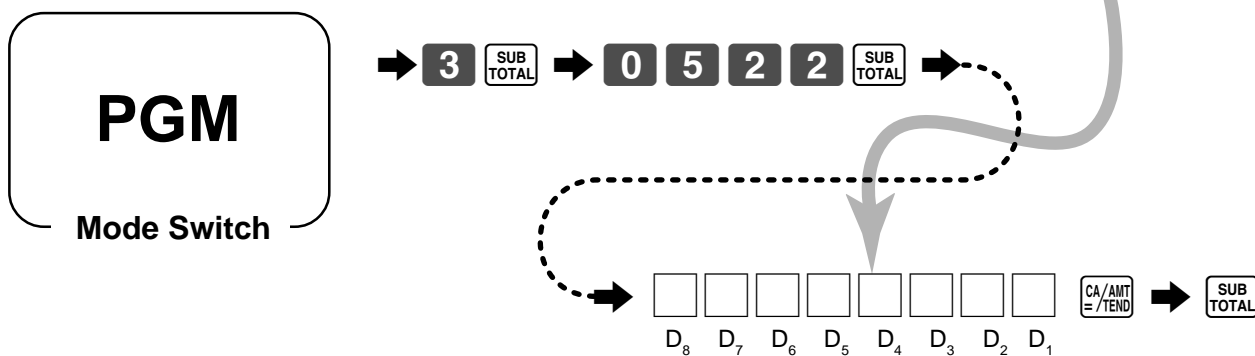

## Programming compulsory and clerk control function

Force <input type="checkbox"/> <b>SUB TOTAL</b> operation before finalization.	a	No = 0 Yes = 2	a+b = <input type="text"/> D <sub>8</sub>
Force a money declaration before allowing a daily read/reset and financial read operation.	b	No = 0 Yes = 4	
Always "00"			<input type="text"/> <input type="text"/> D <sub>7</sub> D <sub>6</sub>
Multiplication procedure: ① Quantity × amount, ② Amount × quantity		① = 0 ② = 2	<input type="text"/> D <sub>5</sub>
Clear the key buffer when a receipt is issued.	a	No = 0 Yes = 1	a+b+c = <input type="text"/> D <sub>4</sub>
Perform auto sign-off when a receipt/report is issued.	b	No = 0 Yes = 2	
Restriction (to 0, 5) on last amount digit of cash sales, received on account, paid out and money declaration (only for Australia)	c	No = 0 Yes = 4	
Display "seconds" during time display.		No = 0 Yes = 2	<input type="text"/> D <sub>3</sub>
Reset the consecutive number when the daily reset report is issued.	a	Yes = 0 No = 1	a+b = <input type="text"/> D <sub>2</sub>
Prohibit cancel operation.	b	No = 0 Yes = 2	
Assign <input type="text"/> <input type="text"/> as "00" or "000".	a	"00" = 0 "000" = 1	a+b = <input type="text"/> D <sub>1</sub>
Use "clerk" function. (If you select "Yes", sign on operation is necessary before registration.)	b	No = 0 Yes = 4	

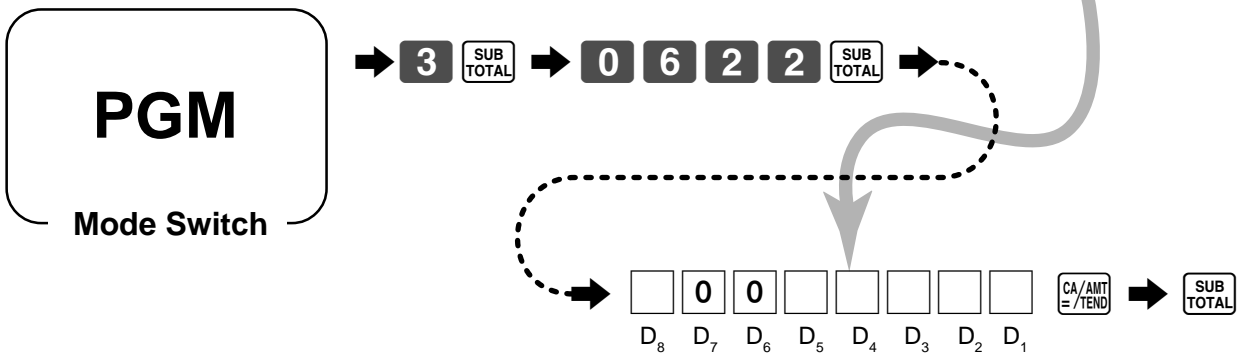

# Convenient Operations and Setups

## Programming read/reset report printing control

Print the first and the last consecutive number of the day (consecutive No. range) on the daily sales reset report.		No = 0 Yes = 4	<input type="checkbox"/> D <sub>6</sub>
Skip zero total lines on department and transaction read/reset report.	a	Yes = 0 No = 1	a+b+c = <input type="checkbox"/> D <sub>5</sub>
Skip zero total lines on PLU read/reset report.	b	Yes = 0 No = 2	
Skip zero total lines on hourly sales report.	c	Yes = 0 No = 4	
Print the sales ratio on read/reset report.	a	No = 0 Yes = 1	a+b = <input type="checkbox"/> D <sub>4</sub>
Suppress printing of the non-resettable grand total on the daily reset report.	b	No = 0 Yes = 2	a+b = <input type="checkbox"/> D <sub>3</sub>
Suppress printing of RF total and count (both RF mode and RF key) on the read/reset report.	a	No = 0 Yes = 1	
Print tax rate with tax totalizer.	b	No = 0 Yes = 2	
Always "00"			<input type="checkbox"/> 0 <input type="checkbox"/> 0 D <sub>2</sub> D <sub>1</sub>

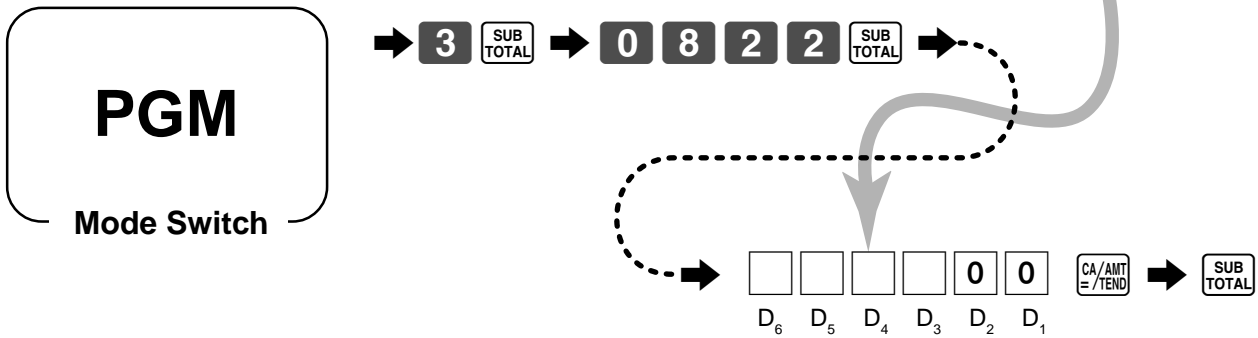

## Setting a store/machine number

You can set a 4-digit machine number to identify your machine. The machine number is printed on receipts/journal for each transaction.

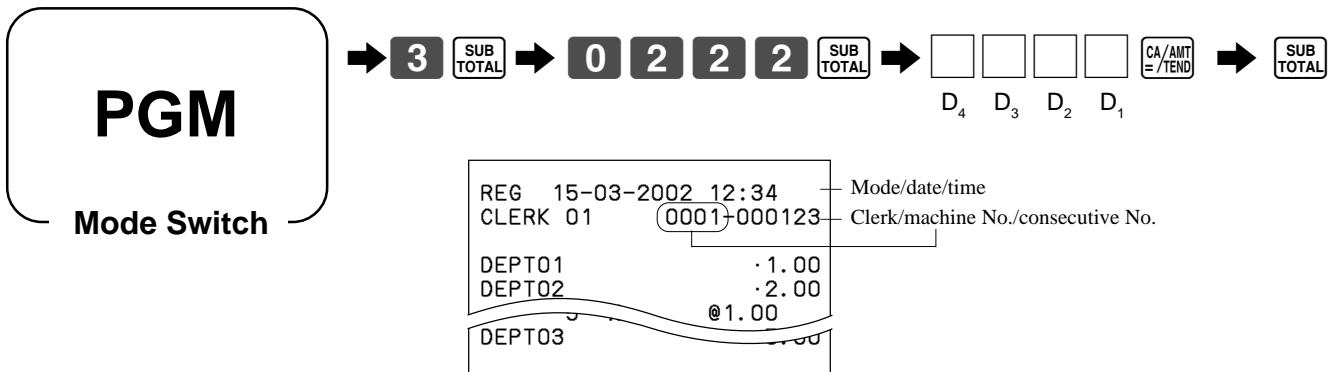

# Programming to clerk

You can program up to 4-digit assigning number (clerk number) and trainee status of clerk (i.e. training cashier) for each clerk.

## Programming clerk number

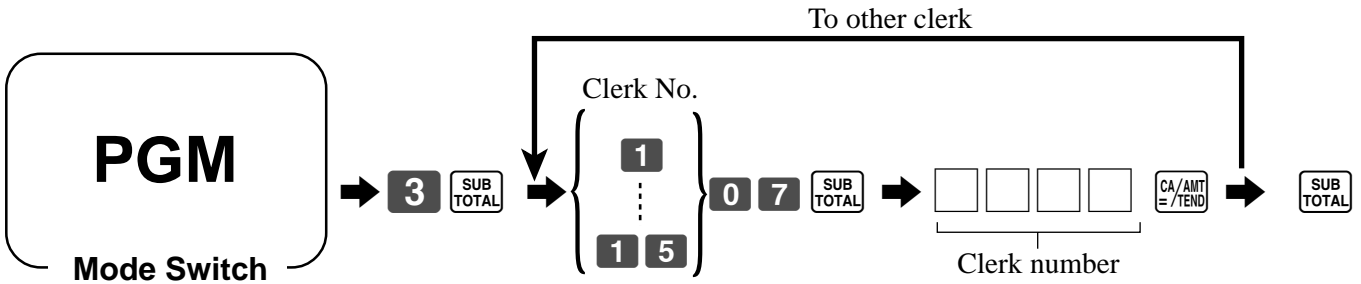

## Programming trainee status of clerk

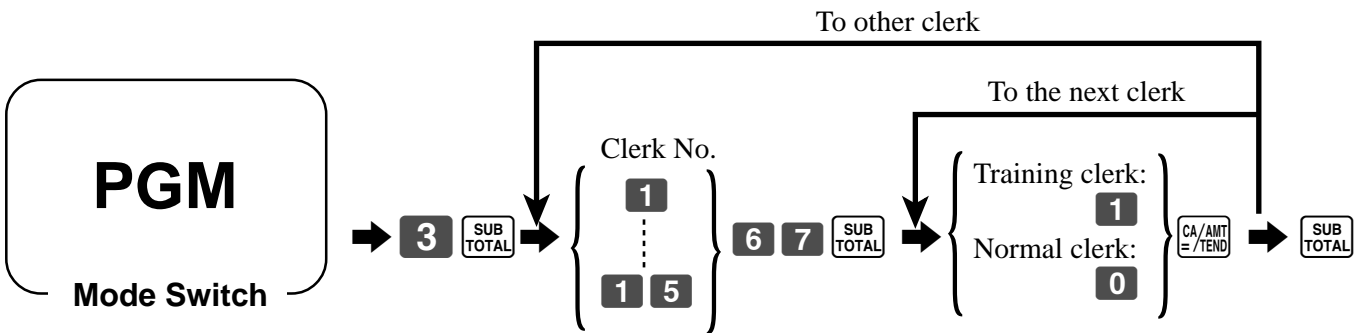

When a training clerk signs on, the cash register automatically enters the training mode. In the training mode, no operations are affected on any totalizers nor counters. The training mode symbols are printed in the columns of receipt entries produced in the training mode. The cash register exits the training mode when the training clerk signs off.



### Grand total, special character

Memory No.	Program code	Contents	Initial character	Yours					
01	20	Grand total	GRND TTL						
01	23	Amount/@/No./Quantity (2 each)	· @NoQT						
		Amount/@/No./Quantity (Australian GST) (2 each)	\$ @NoQT						
02		Item count/Customer (2 each)	NoCT						
03		Multiplication/Split pricing (2 each)	X /						
04		Taxable status 1 ~ 4 (2 each)	T1T2T3T4						
		Taxable status 1 (Australian GST) (2 each)	* T2T3T4						
05		All taxable status	*						
06		Foreign currency symbol (2 each)	* *						
07		REG mode/Refund mode (4 each)	REG RF						
08		not used (4)/Program mode (3)	PGM n (n=1~6)						
09		X/Z mode (4 each)	X Z						
10		CAL mode (4)	CAL						
11		Training mode	****						
12		Training symbol	*****						
13		Total symbol (Tendering)	TOTAL						
14		Change symbol	CHANGE						
15		not used							
16		Total symbol (Post receipt)	TOTAL						
17		Total symbol (% registration)	ST						
18		AM, PM (3 each)	AM PM						
19		Tax total	TAX						
20		Auto-program data sending	SEND PGM						
21		Auto-program data receiving	RECV PGM						
22	Auto-program	PGM							
23	Auto-program normal end message	END							
24	Auto-program error end message	ERROR							
25	Auto-program forced end message	**END**							
26	Total message on report	TOTAL							

### Report title

Memory No.	Program code	Contents	Initial character	Yours					
01	24	Daily report title	DAILY						
02		PLU report title	PLU						
03		Hourly sales report title	HOURLY						
04		Group report title	GROUP						
05		Not used	CLERK						
06		Financial report title	FLASH						
07		Monthly report title	MONTHLY						
08		Periodic-1 report title	PERIODIC-1						
09		Periodic-2 report title	PERIODIC-2						
10		Individual report title							
11		Not used							
12		Not used							

### Clerk name

Memory No.	Program code	Contents	Initial character	Yours					
01	07	Clerk 01	CLERK 01						
02		Clerk 02	CLERK 02						
03		Clerk 03	CLERK 03						
04		Clerk 04	CLERK 04						
		Clerk 05	CLERK 05						
15		Clerk 15	CLERK 15						

# Convenient Operations and Setups

## Receipt message

Refer to “Programming receipt message/logo stamp control function” on page 52.

Memory No.	Program code	Contents	Initial character	Yours
01	32	1st line of logo message		
02		2nd line of logo message	YOUR RECEIPT	
03		3rd line of logo message	THANK YOU	
04		4th line of logo message	CALL AGAIN	
05		5th line of logo message		
06		6th line of logo message		
07		1st line of commercial message		
08		2nd line of commercial message		
09		3rd line of commercial message		
10		4th line of commercial message		
11		5th line of commercial message		
12		1st line of bottom message		
13		2nd line of bottom message		
14		3rd line of bottom message		
15		4th line of bottom message		
16		5th line of bottom message		
17		1st line of Australian MOF msg.	TAX INVOICE	
18		2nd line of Australian MOF msg.	* INDICATES	
19		3rd line of Australian MOF msg.	TAXABLE SUPPLY	

## Programming department key descriptor

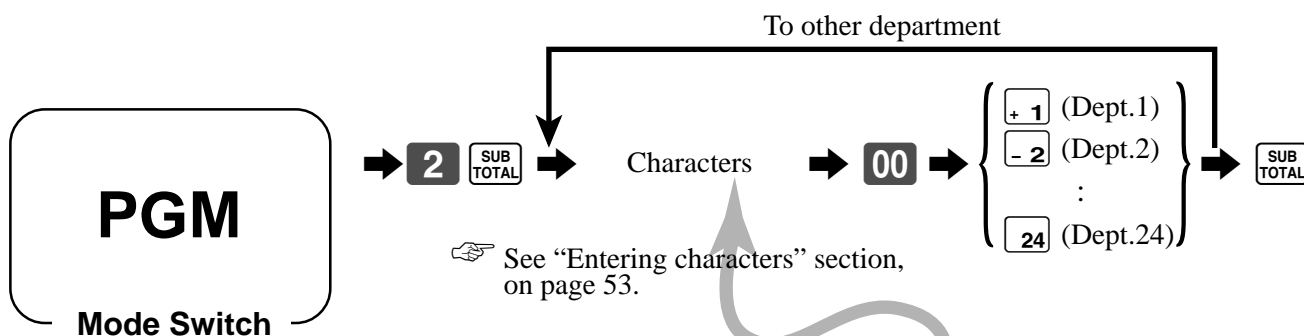

Contents	Initial character	Yours
Department 01	DEPT01	
Department 02	DEPT02	
Department 03	DEPT03	
Department 04	DEPT04	
Department 05	DEPT05	
Department 06	DEPT06	
Department 07	DEPT07	
Department 08	DEPT08	
Department 09	DEPT09	
Department 10	DEPT10	
Department 11	DEPT11	
Department 12	DEPT12	
Department 13	DEPT13	
Department 14	DEPT14	
Department 15	DEPT15	
Department 16	DEPT16	
Department 17	DEPT17	
Department 23	DEPT23	
Department 24	DEPT24	

# Programming PLU descriptor

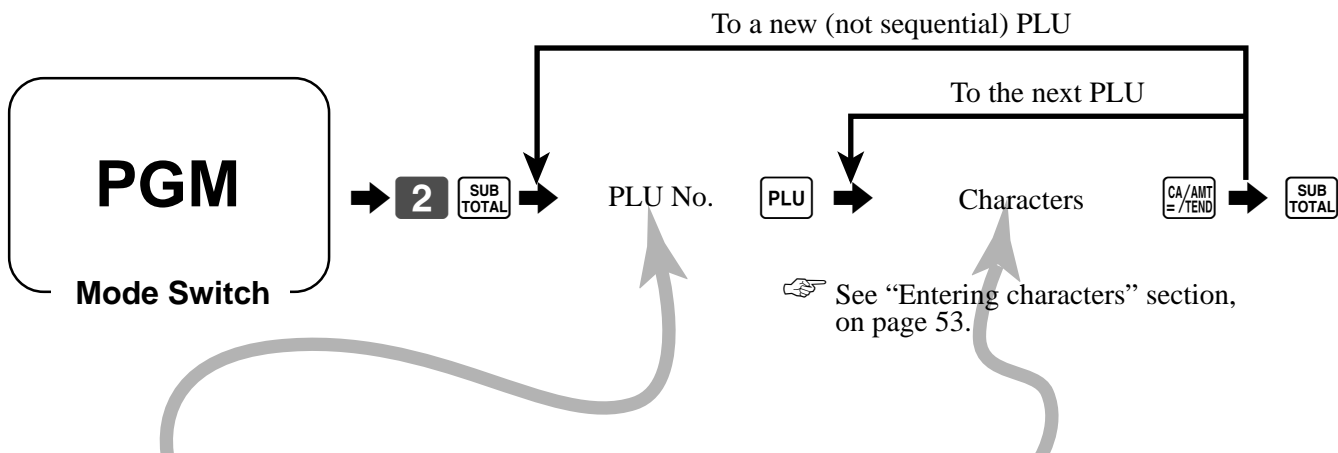

PLU No.	Contents	Initial character	Yours
001	PLU001	PLU0001	
002	PLU002	PLU0002	
003	PLU003	PLU0003	
004	PLU004	PLU0004	
005	PLU005	PLU0005	
006	PLU006	PLU0006	
007	PLU007	PLU0007	
008	PLU008	PLU0008	
009	PLU009	PLU0009	
010	PLU010	PLU0010	
011	PLU011	PLU0011	
012	PLU012	PLU0012	
013	PLU013	PLU0013	
014	PLU014	PLU0014	
015	PLU015	PLU0015	
016	PLU016	PLU0016	
017	PLU017	PLU0017	
018	PLU018	PLU0018	
019	PLU019	PLU0019	
020	PLU020	PLU0020	
021	PLU021	PLU0021	
022	PLU022	PLU0022	
023	PLU023	PLU0023	
024	PLU024	PLU0024	
025	PLU025	PLU0025	
026	PLU026	PLU0026	
027	PLU027	PLU0027	
028	PLU028	PLU0028	
029	PLU029	PLU0029	
030	PLU030	PLU0030	
031	PLU031	PLU0031	
032	PLU032	PLU0032	
033	PLU033	PLU0033	
034	PLU034	PLU0034	
035	PLU035	PLU0035	
036	PLU036	PLU0036	
037	PLU037	PLU0037	
038	PLU038	PLU0038	
039	PLU039	PLU0039	
1498	PLU1498	PLU1498	
1499	PLU1499	PLU1499	
1500	PLU1500	PLU1500	

# Convenient Operations and Setups

## Programming function key descriptor

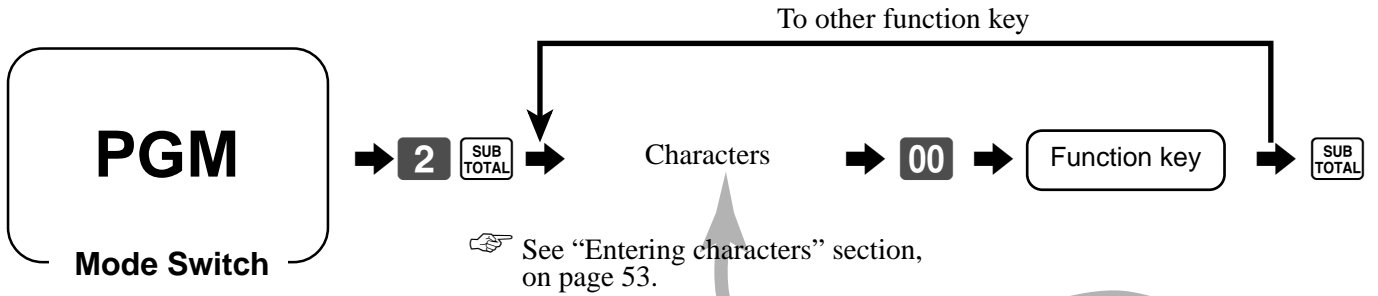

Contents	Initial character	Yours
Cash/amount tendered	CASH	
Charge	CHARGE	
Check	CHECK	
Received on account	RC	
Paid out	PD	
Minus	-	
Discount	%-	
Premium	%+	
Refund	REFUND	
Error correct/Cancel	ERR CORR	
Non-add/No sale	#/NS	
Post receipt	P/G RCT	
Currency exchange 1	EXCHG1	
Currency exchange 2	EXCHG2	
VAT	VAT	
Price	PRICE	
Open	OPEN	
Clerk No.	SIGN/ON	
Subtotal	TL	
Receipt on/off	R ON/OFF	
Multiplication/Date time	X	

## Programming receipt message/logo stamp control function

① Print graphic logo (electronic logo stamp), ② Logo message	a	① = 0 ② = 1	
Print commercial message.	b	No = 0 Yes = 2	
Print bottom message.	c	No = 0 Yes = 4	
Always "0000000"			

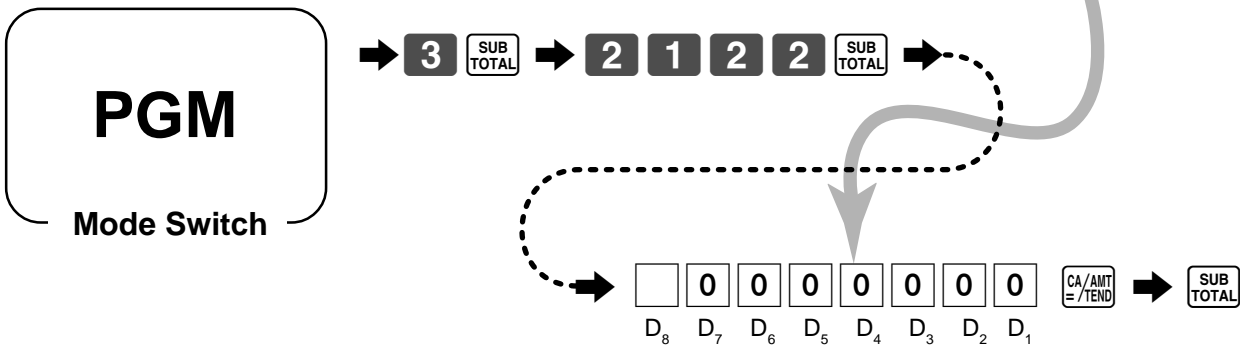

# Entering characters

In this section, the method to enter descriptors or messages (characters) to the cash register during programming is described.

Characters are specified by character keyboard or by codes. In the first half of this section, the usage of character keyboard is described. In the latter half, inputting method by character code is described.

## Using character keyboard

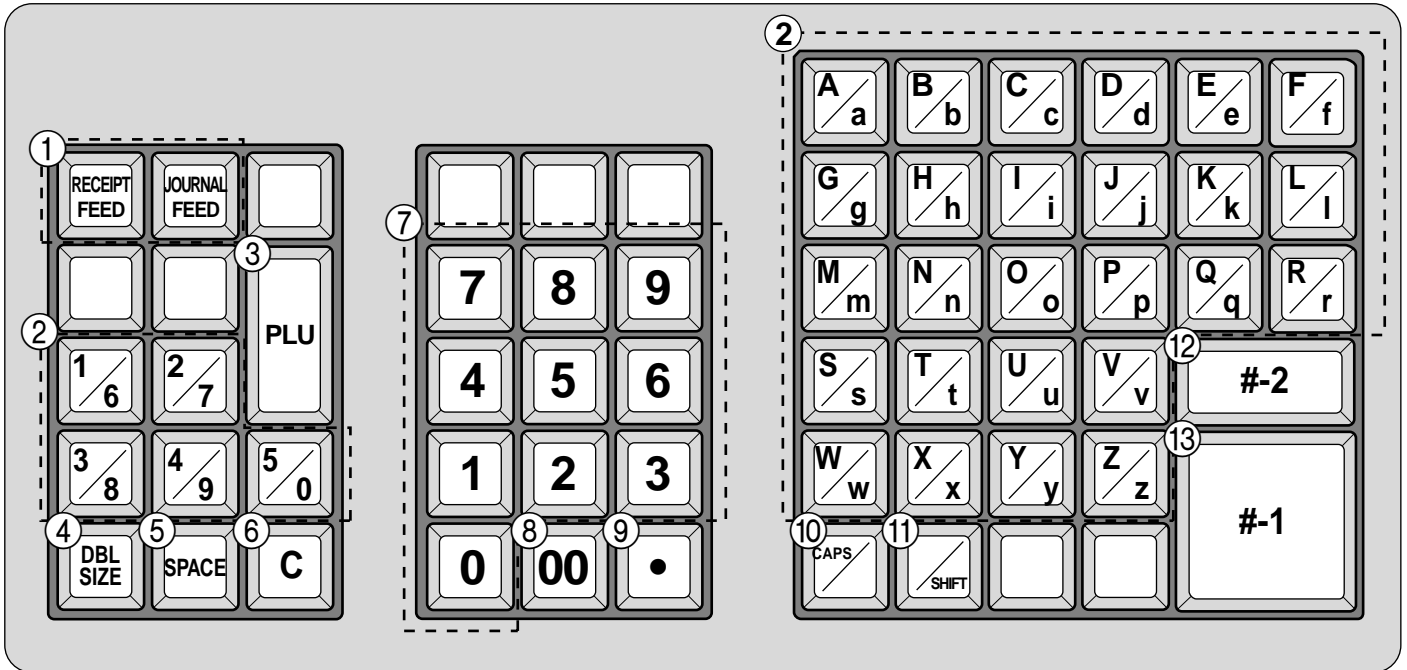

- ① **Feed key**  
Hold this key down to feed paper from the printer.
- ② **Alphabet keys**  
Used input to characters.
- ③ **PLU key**  
Use this key to input PLU numbers.
- ④ **Double size letter key**  
Specifies that the next character you input to a double size character. You must press this key before each double size character.
- ⑤ **Space key**  
Set a space by depression.
- ⑥ **Clear key**  
Clears all input characters in the programming.
- ⑦ **Numeric keys**  
Used to enter program codes, memory number and character codes.
- ⑧ **Character fixed key**  
Enter when the alphabetic entry for a descriptor, name or message has been completed.
- ⑨ **Backspace/Character code fixed key**  
Registers one character with code (2 or 3 digits). Clears the last input character, much like a back space key.
- ⑩ **CAPS key**  
Pressing this key shifts the character from the lowercase letter to upper case letter.
- ⑪ **Shift key**  
Pressing this key shifts the character from the uppercase letter to lower case letter.
- ⑫ **Program end key**  
Terminates the character programming.
- ⑬ **Character enter key**  
Registers the programmed characters.

### Example:



















Input “ **A** p p l e J u i c e ”,  
enter “DBL SIZE”, “A”, “SHIFT”, “p”, “p”, “l”, “e”, “SPACE”, “CAPS”, “J”, “SHIFT”, “u”, “i”, “c”, “e” .

# Convenient Operations and Setups

## Entering characters by code







Every time you enter a character, choose character codes by the character code list (below) and press the  key to settle it.

### Example:

Input “  p  p  e  u  c  ”,  
 enter “ 255  65  112  112  108  101  32  74  117  105  99  101  ”.

## Character code list

Chara	Code	Chara	Code	Chara	Code	Chara	Code	Chara	Code	Chara	Code	Chara	Code
Space	32	0	48	@	64	P	80	'	96	p	112	Ç	128
!	33	1	49	A	65	Q	81	a	97	q	113	ü	129
"	34	2	50	B	66	R	82	b	98	r	114	é	130
#	35	3	51	C	67	S	83	c	99	s	115	â	131
\$	36	4	52	D	68	T	84	d	100	t	116	ä	132
%	37	5	53	E	69	U	85	e	101	u	117	à	133
&	38	6	54	F	70	V	86	f	102	v	118	â	134
'	39	7	55	G	71	W	87	g	103	w	119	ç	135
(	40	8	56	H	72	X	88	h	104	x	120	ê	136
)	41	9	57	I	73	Y	89	i	105	y	121	ë	137
*	42	:	58	J	74	Z	90	j	106	z	122	è	138
+	43	;	59	K	75	[	91	k	107	{	123	ï	139
,	44	<	60	L	76	\	92	l	108		124	î	140
-	45	=	61	M	77	]	93	m	109	}	125	ì	141
.	46	>	62	N	78	^	94	n	110	~	126	Ä	142
/	47	?	63	O	79	_	95	o	111		127	Å	143

É	144	á	160		176	Ł	192	ð	208	Ó	224	-	240
æ	145	í	161		177	ł	193	Ð	209	ó	225	±	241
Æ	146	ó	162		178	ŧ	194	Ê	210	Ô	226	_	242
ô	147	ú	163		179	†	195	Ë	211	Ò	227	3/4	243
ö	148	ñ	164	‡	180	—	196	È	212	õ	228	¶	244
ò	149	Ñ	165	Á	181	†	197	€	213	Õ	229	§	245
û	150	ª	166	Â	182	ã	198	í	214	µ	230	÷	246
ù	151	º	167	Ã	183	Ä	199	î	215	þ	231	,	247
ÿ	152	¿	168	©	184	Ł	200	ï	216	Ɔ	232	°	248
Ö	153	®	169	†	185	ł	201	Ɔ	217	Ú	233	¨	249
Ü	154	¬	170		186	ł	202	Ɔ	218	Û	234	•	250
ø	155	1/2	171	ŧ	187	ŧ	203		219	Ù	235	¹	251
£	156	1/4	172	Ɔ	188	†	204		220	ý	236	³	252
Ø	157	¡	173	¢	189	—	205		221	Ý	237	²	253
×	158	«	174	¥	190	†	206	ì	222	—	238		254
f	159	»	175	ı	191	¤	207		223	'	239	Double size	255

 : for R/J printer only.

The “Ä”, “Ö”, “Ü” characters are displayed as “A”, “O”, “U”.

# Department key feature programming

There are two different methods you can use to assign features to department keys. With “Batch feature programming”, you can use a single operation to assign multiple features. “Individual feature programming”, on the other hand, let you assign features one-by-one. This method is recommended for programming of special features to individual department keys.

## Batch feature programming

When using this procedure to assign multiple features to departments, use 9-digit codes that you create using the following procedure

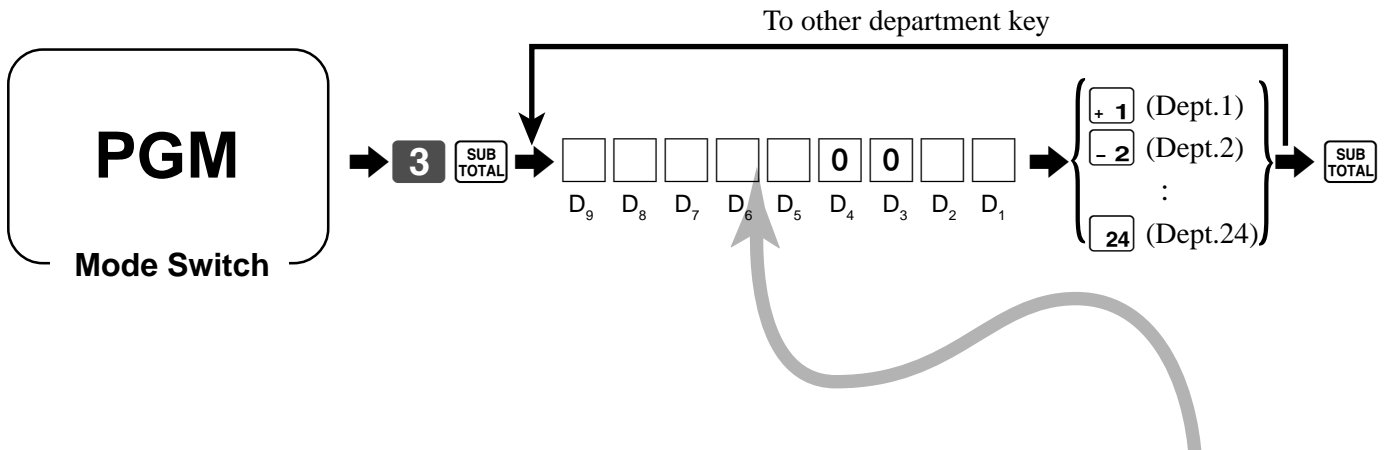

Negative department	a	No = 0 Yes = 2	a+b = <input type="text"/> D <sub>9</sub>
Hash department	b	No = 0 Yes = 4	
Single item sale		No = 0 Yes = 1	<input type="text"/> D <sub>8</sub>
High digit limit specification		Significant number	<input type="text"/> D <sub>7</sub>
Taxable status 1	a	No = 0 Yes = 1	a+b+c = <input type="text"/> D <sub>6</sub>
Taxable status 2	b	No = 0 Yes = 2	
Taxable status 3	c	No = 0 Yes = 4	
Taxable status 4		No = 0 Yes = 4	<input type="text"/> D <sub>5</sub>
Always “00”			<input type="text"/> 0 <input type="text"/> 0 D <sub>4</sub> D <sub>3</sub>
Group link (00 ~ 50)		Significant numbers	<input type="text"/> <input type="text"/> D <sub>2</sub> D <sub>1</sub>

# Convenient Operations and Setups

## Individual feature programming

With this procedure, you can assign individual features to specific departments. Please select the command code of the contents you want to program, and follow the procedure below.

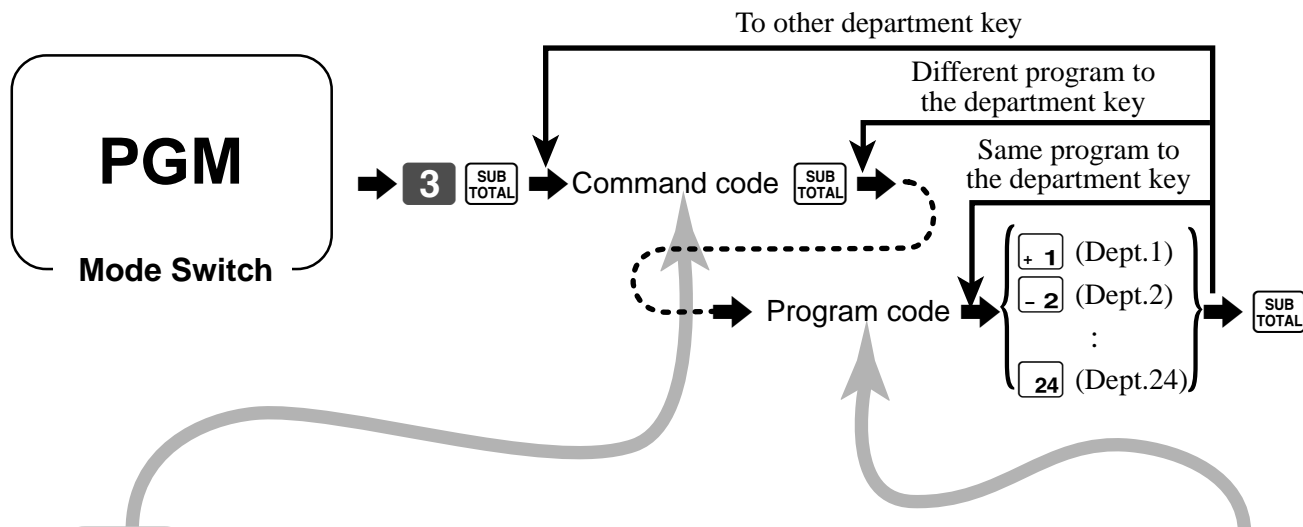

Command code	Contents/selection			Program code
0166	Negative department	a	No = 0 Yes = 2	a+b = <input type="text"/>
	Hash department	b	No = 0 Yes = 4	
1866	Single item sale		No = 0 Yes = 1	<input type="text"/>
1566	High digit limit specification		Significant number	<input type="text"/>
0366	Taxable status 1	a	No = 0 Yes = 1	a+b+c = <input type="text"/>
	Taxable status 2	b	No = 0 Yes = 2	
	Taxable status 3	c	No = 0 Yes = 4	
0966	Taxable status 4		No = 0 Yes = 4	<input type="text"/>
1166	Group link (00 ~ 50)		Significant numbers	<input type="text"/> <input type="text"/>

To program a unit price to a department key, please refer the page 26.

# PLU feature programming

There are two different methods you can use to assign features to PLUs. With “Batch feature programming”, you can use a single operation to assign multiple features. “Individual feature programming”, on the other hand, let you assign features one-by-one. This method is recommended for programming of special features to individual PLUs.

## Batch feature programming

When using this procedure to assign multiple features to PLUs, use 9-digit codes that you create using the following procedure.

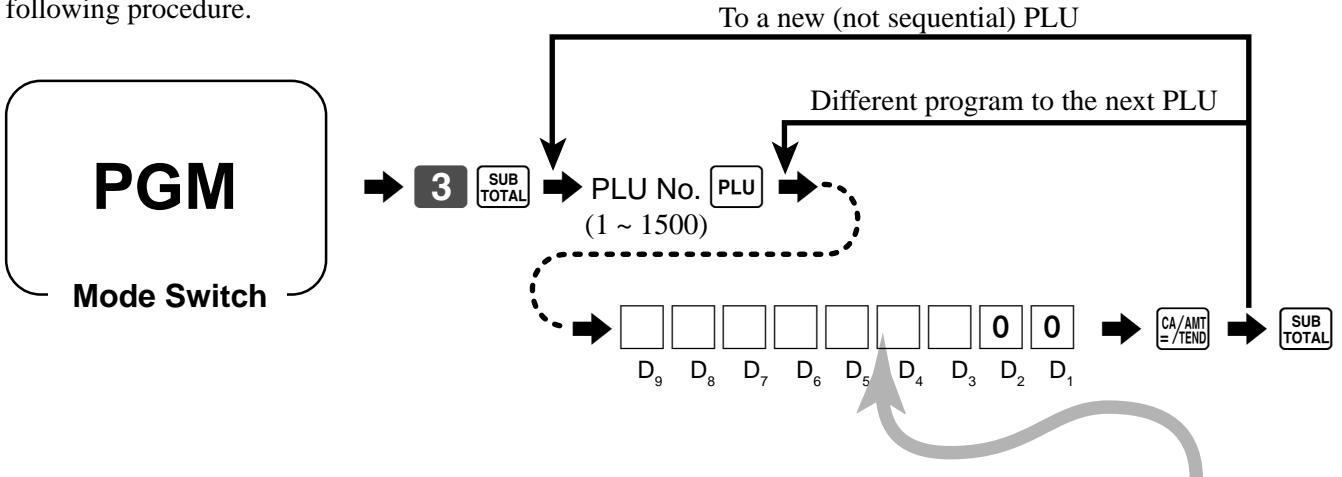

Negative PLU	a	No = 0 Yes = 2	$a+b = \square D_9$
Hash PLU	b	No = 0 Yes = 4	
Single item sale	a	No = 0 Yes = 1	$a+b = \square D_8$
Treat as subdepartment/PLU.	b	PLU = 0 Subdept. = 4	
High digit limit specification (for subdepartment)		Significant number	$\square D_7$
Taxable status 1	a	No = 0 Yes = 1	$a+b+c = \square D_6$
Taxable status 2	b	No = 0 Yes = 2	
Taxable status 3	c	No = 0 Yes = 4	
Taxable status 4		No = 0 Yes = 4	$\square D_5$
Department link (00 ~ 24)		Significant numbers	$\square \square D_4 D_3$
Always “00”			$00 D_2 D_1$

# Convenient Operations and Setups

## Individual feature programming

With this procedure, you can assign individual features to specific PLUs. Please select the command code of the contents you want to program, and follow the procedure below.

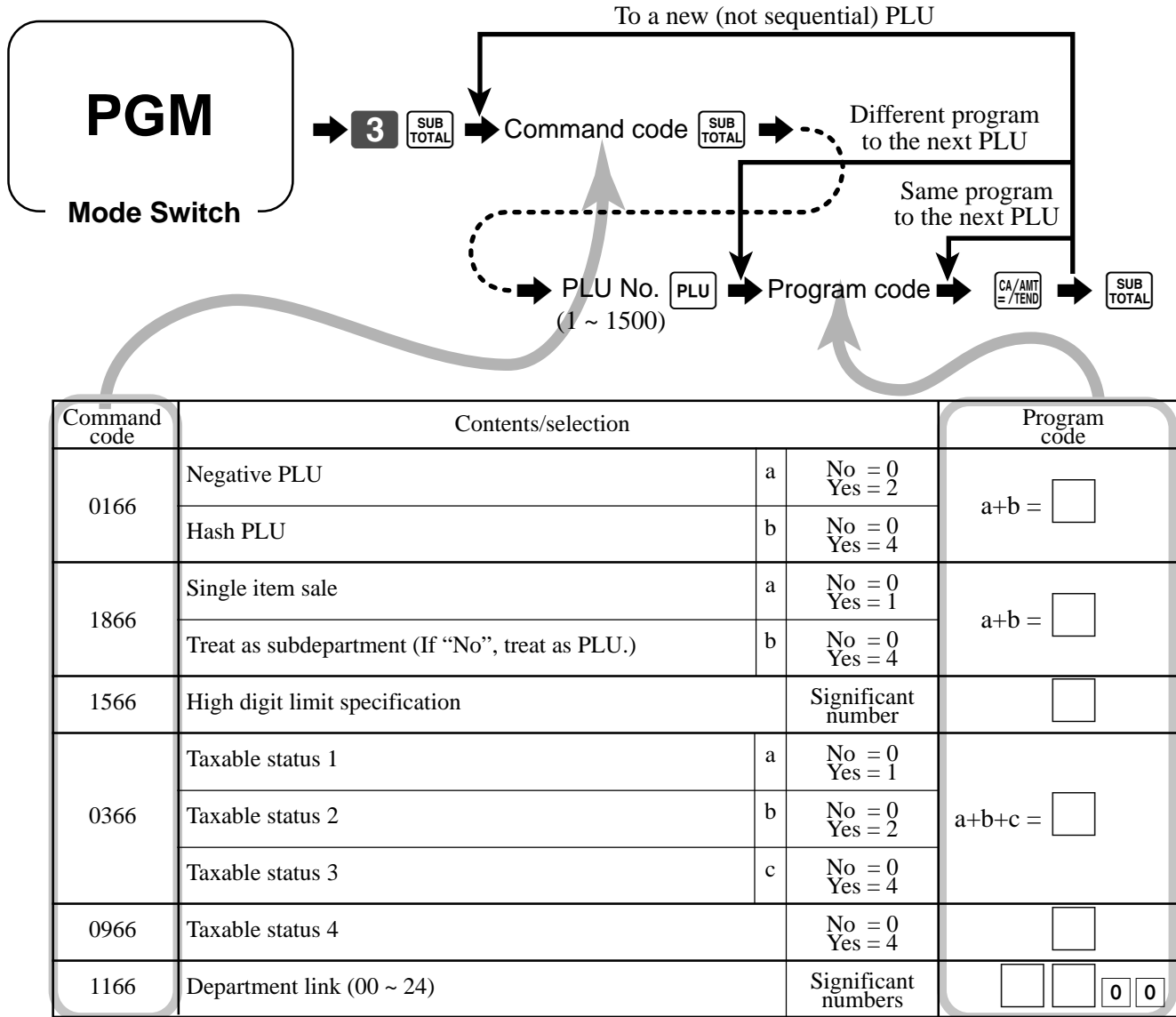

To program a unit price to a PLU or a subdepartment, please refer to the page 28.

## Registering example

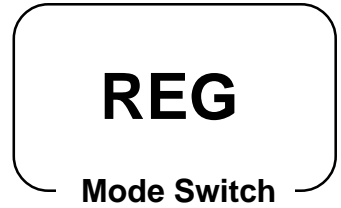

### Locking out and releasing high digit limitation

	OPERATION	RECEIPT												
<table border="1" style="width: 100%; border-collapse: collapse;"> <tr> <td rowspan="4" style="text-align: center;">Item</td> <td>Unit price</td> <td style="text-align: right;">\$10.50</td> </tr> <tr> <td>Quantity</td> <td style="text-align: center;">1</td> </tr> <tr> <td>Dept.</td> <td style="text-align: center;">3</td> </tr> <tr> <td>Max. digit</td> <td style="text-align: center;">(3)</td> </tr> <tr> <td>Payment</td> <td>Cash</td> <td style="text-align: right;">\$11.00</td> </tr> </table> <p>( ): Preset value</p>	Item	Unit price	\$10.50	Quantity	1	Dept.	3	Max. digit	(3)	Payment	Cash	\$11.00	<div style="margin-bottom: 10px;"> <span style="font-size: 24px; font-weight: bold;">1 0 5 0</span> <span style="border: 1px solid black; padding: 2px;">x 3</span>  <b>ERROR ALARM</b>                      (Exceeding max. digits)                 </div> <div style="margin-bottom: 10px;"> <span style="border: 1px solid black; padding: 2px;">C</span>  <small>CIAC</small> </div> <div style="margin-bottom: 10px;"> <span style="border: 1px solid black; padding: 2px;">OPEN</span> </div> <p style="font-size: 10px;">Cancels limitations for next entry</p> <div style="margin-bottom: 10px;"> <span style="font-size: 24px; font-weight: bold;">1 0 5 0</span> <span style="border: 1px solid black; padding: 2px;">x 3</span> </div> <div style="margin-bottom: 10px;"> <span style="border: 1px solid black; padding: 2px;">SUB TOTAL</span> </div> <div> <span style="font-size: 24px; font-weight: bold;">1 1 00</span> <span style="border: 1px solid black; padding: 2px;">CA/AMT =/TEND</span> </div>	<div style="border: 1px solid black; padding: 5px; width: fit-content; margin: 0 auto;">                 REG 15-03-2002 12:40                  CLERK 01 000030                   DEPT03 .10.50                  TOTAL .10.50                  CASH .11.00                  CHANGE .0.50             </div>
Item		Unit price	\$10.50											
		Quantity	1											
		Dept.	3											
	Max. digit	(3)												
Payment	Cash	\$11.00												

### Single item sales items

You can issue a receipt by simply touching the single item sales department or PLU. The following examples show how you register single-item-sale departments. Registration of single item sale PLUs is identical.

#### Single item

	OPERATION	RECEIPT									
<table border="1" style="width: 100%; border-collapse: collapse;"> <tr> <td rowspan="4" style="text-align: center;">Item</td> <td>Unit price</td> <td style="text-align: right;">\$2.00</td> </tr> <tr> <td>Quantity</td> <td style="text-align: center;">1</td> </tr> <tr> <td>Dept.</td> <td style="text-align: center;">4</td> </tr> <tr> <td>Sales status</td> <td style="text-align: center;">(Single item)</td> </tr> </table> <p>( ): Preset value</p>	Item	Unit price	\$2.00	Quantity	1	Dept.	4	Sales status	(Single item)	<div style="margin-bottom: 10px;"> <span style="font-size: 24px; font-weight: bold;">2 00</span> <span style="border: 1px solid black; padding: 2px;">÷ 4</span> </div>	<div style="border: 1px solid black; padding: 5px; width: fit-content; margin: 0 auto;">                 REG 15-03-2002 12:45                  CLERK 01 000031                   DEPT04 .2.00                  CASH .2.00             </div>
Item		Unit price	\$2.00								
		Quantity	1								
		Dept.	4								
	Sales status	(Single item)									

#### Multiple item sale

	OPERATION	RECEIPT																			
<table border="1" style="width: 100%; border-collapse: collapse;"> <tr> <td rowspan="4" style="text-align: center;">Item 1</td> <td>Unit price</td> <td style="text-align: right;">\$2.00</td> </tr> <tr> <td>Quantity</td> <td style="text-align: center;">1</td> </tr> <tr> <td>Dept.</td> <td style="text-align: center;">3</td> </tr> <tr> <td>Sales status</td> <td style="text-align: center;">(Normal)</td> </tr> <tr> <td rowspan="3" style="text-align: center;">Item 2</td> <td>Unit price</td> <td style="text-align: right;">\$5.00</td> </tr> <tr> <td>Quantity</td> <td style="text-align: center;">1</td> </tr> <tr> <td>Dept.</td> <td style="text-align: center;">4</td> </tr> <tr> <td>Payment</td> <td>Cash</td> <td style="text-align: right;">\$7.00</td> </tr> </table> <p>( ): Preset value</p>	Item 1	Unit price	\$2.00	Quantity	1	Dept.	3	Sales status	(Normal)	Item 2	Unit price	\$5.00	Quantity	1	Dept.	4	Payment	Cash	\$7.00	<div style="margin-bottom: 10px;"> <span style="font-size: 24px; font-weight: bold;">2 00</span> <span style="border: 1px solid black; padding: 2px;">x 3</span>  <span style="font-size: 24px; font-weight: bold;">5 00</span> <span style="border: 1px solid black; padding: 2px;">÷ 4</span> </div> <p style="font-size: 10px;">Single item status is not effective during transaction.</p> <div style="margin-bottom: 10px;"> <span style="border: 1px solid black; padding: 2px;">CA/AMT =/TEND</span> </div> <p style="font-size: 10px;">It is necessary to press the finalize key.</p>	<div style="border: 1px solid black; padding: 5px; width: fit-content; margin: 0 auto;">                 REG 15-03-2002 12:50                  CLERK 01 000032                   DEPT03 .2.00                  DEPT04 .5.00                  CASH .7.00             </div>
Item 1		Unit price	\$2.00																		
		Quantity	1																		
		Dept.	3																		
	Sales status	(Normal)																			
Item 2	Unit price	\$5.00																			
	Quantity	1																			
	Dept.	4																			
Payment	Cash	\$7.00																			

Note: The single item sales department or PLU should be registered at the top of the transaction, otherwise the transaction is not finalized. It is necessary to press CA/AMT  
=/TEND, CH or CHK key.

# Convenient Operations and Setups

## Examples of registering subdepartments

### Single item sale

Item	Unit price	\$6.00
	Quantity	1
	Subdept.	15
Payment	Cash	\$10.00

#### OPERATION

1 5   
 PLU (subdepartment) code

6 00   
 Unit price

1 0 00

#### RECEIPT

REG	15-03-2002	12:55
CLERK	01	000033
PLU0015		.6.00
TOTAL		6.00
CASH		10.00
CHANGE		4.00

### Repeat

Item 1	Unit price	(\$3.00)
	Quantity	3
	Subdept.	15
Item 2	Unit price	\$2.00
	Quantity	2
	Subdept.	15
Payment	Cash	\$20.00

( ): Preset value

#### OPERATION

1 5

Hit  without a unit price  
 recalls preset price.

1 5

2 00

2 0 00

#### RECEIPT

REG	15-03-2002	13:00
CLERK	01	000034
PLU0015		.3.00
PLU0015		.3.00
PLU0015		.3.00
PLU0015		.2.00
PLU0015		.2.00
TOTAL		13.00
CASH		20.00
CHANGE		7.00

### Multiplication

Item	Unit price	\$6.00
	Quantity	1.25
	Subdept.	15
Payment	Cash	\$10.00

1 . 2 5   
 Quantity  
 (4-digit integer/2-digit decimal)

1 5

6 00

1 0 00

#### RECEIPT

REG	15-03-2002	13:05
CLERK	01	000035
1.25	X	@6.00
PLU0015		.7.50
TOTAL		7.50
CASH		10.00
CHANGE		2.50

# Printing VAT breakdowns

The following example shows how to get VAT breakdown.  
Anytime you press the **VAT** key in a transaction, VAT breakdown is automatically printed out at the end of the transaction.

**REG**

Mode Switch

## OPERATION

## RECEIPT

Item	Unit price	\$10.00
	Quantity	1
	Dept.	1
	Taxable	(1)
Payment	Cash	\$10.00

( ): Preset value

1 0 00 + 1  
SUB  
TOTAL  
VAT  
1 0 00 CA/AMT  
= /TEND

```
REG 15-03-2002 13:40
CLERK 01 000039
DEPT01 T1 .10.00
TAX-AMT 1 .9.62
TAX 1 .0.38
TOTAL .10.00
CASH .10.00
CHANGE .0.00
```

- Every receipt needs VAT breakdown lines, select the finalize (**CA/AMT**), (**CH**), (**CHK**) key status to “print VAT breakdown”. Refer to page 65.

## Currency exchange programming

When the **CE1** (**CE2**) key is pressed, a current subtotal including tax is converted directly into foreign currency and the result is displayed, and the subsequent finalization is handled using the foreign currency.

The currency exchange function is released by finalizing a transaction, partial tender operation, receipt issuance, or by pressing the **SUB TOTAL** key.

### Currency exchange rate programming

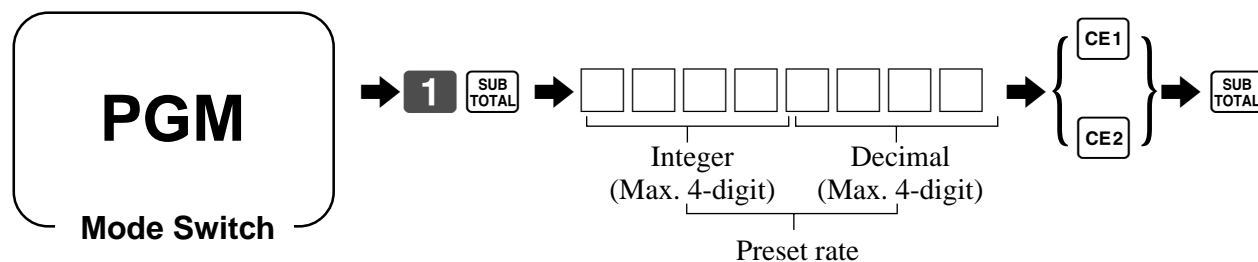

Example:

\$1.00 = ¥110.50 ⇨ **1 · 1 0 5**  
 ¥100 = \$0.9050 ⇨ **0 · 9 0 5**

### Currency exchange feature programming

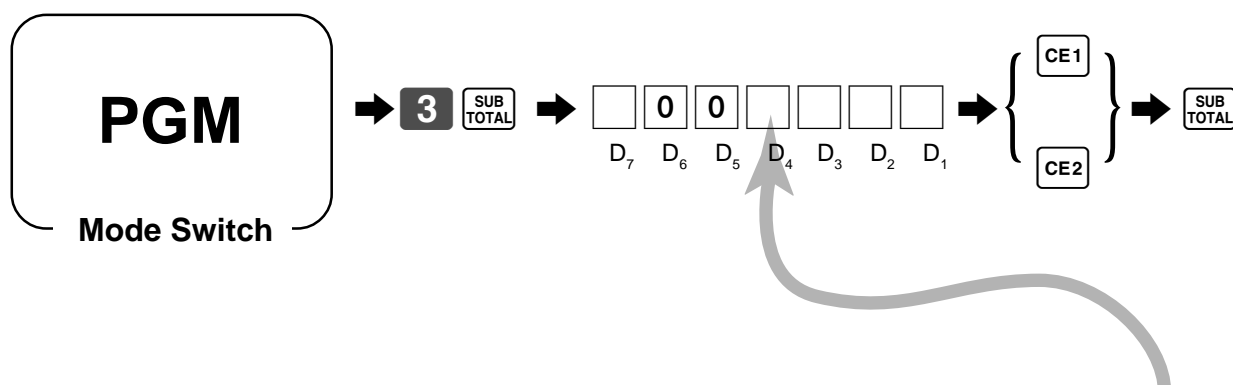

Fraction control, round off = 0, cut off = 1, round up = 2	Significant number	<input type="text"/> D <sub>7</sub>
Always "00"		<input type="text"/> 0 <input type="text"/> 0 D <sub>6</sub> D <sub>5</sub>
Monetary symbol for foreign currency; Local currency symbol = 0 Monetary symbol 1 (in the special character program) = 1 Monetary symbol 2 (in the special character program) = 2	Significant number	<input type="text"/> D <sub>4</sub>
Totalizer selection; ① Currency exchange 1, ② Currency exchange 2	① = 0 ② = 2	<input type="text"/> D <sub>3</sub>
Digit separator for foreign currency; Period = 0, Comma = 2	Significant number	<input type="text"/> D <sub>2</sub>
Monetary system code (decimal places) following currency exchange operation; Same as local currency = 0, <input type="text"/> <input type="text"/> = 1, <input type="text"/> <input type="text"/> <input type="text"/> = 2, <input type="text"/> <input type="text"/> <input type="text"/> <input type="text"/> = 3	Significant number	<input type="text"/> D <sub>1</sub>

## Registering foreign currency

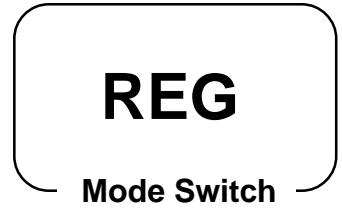

### 1) Full amount tender in foreign currency

\* Preprogrammed exchange rate: ¥ 1 = \$0.0090 to the **CE1** key

#### Important!

Tenders in a foreign currency can be registered using the **CA/AMT = /TEND** and **CHK** keys only. Other finalize keys cannot be used.

OPERATION	DISPLAY	RECEIPT																											
<b>1 0 00</b> <b>+ 1</b> ← Enter the unit price and press the applicable department key.	 (Displays in \$)	<table border="1"> <tr> <td>REG</td> <td>15-03-2002</td> <td>13:20</td> </tr> <tr> <td>CLERK</td> <td>01</td> <td>000038</td> </tr> <tr> <td>DEPT01</td> <td></td> <td>· 10.00</td> </tr> <tr> <td>DEPT02</td> <td></td> <td>· 20.00</td> </tr> <tr> <td>TOTAL</td> <td></td> <td>· 30.00</td> </tr> <tr> <td>EXCHG1</td> <td></td> <td></td> </tr> <tr> <td>CASH</td> <td></td> <td>¥5,000</td> </tr> <tr> <td>CASH</td> <td></td> <td>· 45.00</td> </tr> <tr> <td>CHANGE</td> <td></td> <td>· 15.00</td> </tr> </table>	REG	15-03-2002	13:20	CLERK	01	000038	DEPT01		· 10.00	DEPT02		· 20.00	TOTAL		· 30.00	EXCHG1			CASH		¥5,000	CASH		· 45.00	CHANGE		· 15.00
REG	15-03-2002		13:20																										
CLERK	01		000038																										
DEPT01			· 10.00																										
DEPT02			· 20.00																										
TOTAL		· 30.00																											
EXCHG1																													
CASH		¥5,000																											
CASH		· 45.00																											
CHANGE		· 15.00																											
<b>2 0 00</b> <b>- 2</b> ← Enter the next unit price and press the applicable department key.	 (Displays in \$)																												
<b>CE1</b> ← Press the <b>CE1</b> key without entering a numeric value. This operation converts the subtotal (including tax) dollar value into yen by applying a preprogrammed exchange rate. The result is shown on the display but not printed on the receipt nor journal.	 (Displays in ¥: 3,333)																												
<b>5 0 00</b> <b>CE1</b> ← Enter the amount tendered in yen and press the <b>CE1</b> key. This operation converts the entered yen amount into dollars by applying a preprogrammed exchange rate. The result is shown on the display.	 (Displays in \$: 45.00)																												
<b>CA/AMT = /TEND</b> ← Press to finalize the transaction. Note that you do not need to reenter the dollar amount. The register automatically calculates the change amount due in dollars and shows it on the display, receipts and journal.	 (Displays in \$)																												

# Convenient Operations and Setups

## 2) Partial tender in a foreign currency

\* Preprogrammed exchange rate: ¥ 1 = \$0.0090 to the **CE1** key

### Important!

Partial tender in a foreign currency can be registered using the **CA/AMT = /TEND** key and **CHK** keys only. Other finalization keys cannot be used, but the remaining tender can be finalized using any finalize key.

OPERATION	DISPLAY	RECEIPT																		
<b>1 0 00</b> <b>+ 1</b> ← Enter the unit price and press the applicable department key.	<b>10.00</b> (Displays in \$)	<table border="1"> <tr> <td>REG</td> <td>15-03-2002 13:25</td> </tr> <tr> <td>CLERK</td> <td>01 000039</td> </tr> <tr> <td>DEPT01</td> <td>· 10.00</td> </tr> <tr> <td>DEPT02</td> <td>· 20.00</td> </tr> <tr> <td>TOTAL</td> <td>· 30.00</td> </tr> <tr> <td>EXCHG1</td> <td></td> </tr> <tr> <td>CASH</td> <td>¥2,000</td> </tr> <tr> <td>CASH</td> <td>· 18.00</td> </tr> <tr> <td>CHECK</td> <td>· 12.00</td> </tr> </table>	REG	15-03-2002 13:25	CLERK	01 000039	DEPT01	· 10.00	DEPT02	· 20.00	TOTAL	· 30.00	EXCHG1		CASH	¥2,000	CASH	· 18.00	CHECK	· 12.00
REG	15-03-2002 13:25																			
CLERK	01 000039																			
DEPT01	· 10.00																			
DEPT02	· 20.00																			
TOTAL	· 30.00																			
EXCHG1																				
CASH	¥2,000																			
CASH	· 18.00																			
CHECK	· 12.00																			
<b>2 0 00</b> <b>- 2</b> ← Enter the next unit price and press the applicable department key.	<b>20.00</b> (Displays in \$)																			
<b>CE1</b> ← Press the <b>CE1</b> key without entering a numeric value. This operation converts the subtotal (including tax) dollar value into yen by applying a preprogrammed exchange rate. The result is shown on the display but not printed on the receipt nor journal.	<b>3333</b> (Displays in ¥: 3,333)																			
<b>2 0 00</b> <b>CE1</b> ← Enter the partial amount tendered in yen and press the <b>CE1</b> key. This operation converts the entered yen amount into dollars by applying a preprogrammed exchange rate. The result is shown on the display.	<b>18.00</b> (Displays in \$: 18.00)																			
<b>CA/AMT = /TEND</b> ← Press the <b>CA/AMT = /TEND</b> key to specify cash tender for the yen partial tender. Note that you do not need to reenter the dollar amount. The register automatically deducts the dollar equivalent of the yen amount tendered from the total amount due and shows the amount on the display.	<b>12.00</b> (Displays in \$)																			
<b>CHK</b> ← Press to finalize the transaction.	<b>12.00</b> (Displays in \$)																			

# Other function key feature programming

You can define a selection of features for the function keys by specifying an 8-digit program code for each key.

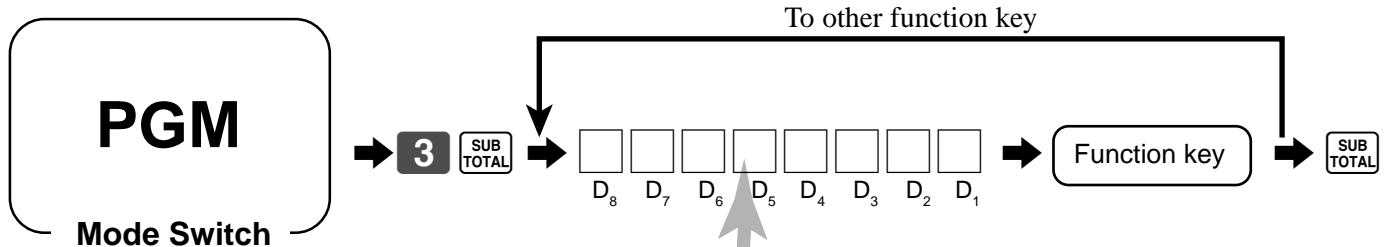

## Cash, Charge, Check key

Restrict (to 0, 5) on the last digit for amount tendered (except <small>CA/AMT = TEND</small> ) (only for Australia)	No = 0 Yes = 1	<input type="text"/> D <sub>8</sub>
Always "0"		<input type="text" value="0"/> D <sub>7</sub>
High amount limit specification for subtotal and tendering amounts *1	Maximum value (0 ~ 9)	<input type="text"/> <input type="text"/> D <sub>6</sub> D <sub>5</sub>
	Number of zeros (0 ~ 9)	
Prohibit entry of a partial payment	a No = 0 Yes = 1	a+b+c = <input type="text"/> D <sub>4</sub>
Prohibit the entry of the amount tendered.	b No = 0 Yes = 2	
Force entry of the amount tendered.	c No = 0 Yes = 4	
Print VAT breakdown.	a No = 0 Yes = 1	a+b = <input type="text"/> D <sub>3</sub>
Restriction (to 00, 25, 50, 75) on last two digits for amount tendered *2	b No = 0 Yes = 4	
High amount limit specification for change amount due. *1	Maximum value (0 ~ 9)	<input type="text"/> <input type="text"/> D <sub>2</sub> D <sub>1</sub>
	Number of zeros (0 ~ 9)	

\*1 High amounts limits:

High amount limitations are specified as 2-digits. The first digit you specify limits the maximum value of the leftmost digit of the value within the range of 0 through 9. The second digit you specify indicates the number of zeros in the limit value, again within the range of 0 through 9.

Example: \$600.00 maximum ⇨ Enter 64.

Entering "00" clears the limitation.

\*2 Always program "Restrict = 4" here for cash amount tendered key when you are using Danish rounding.

# Convenient Operations and Setups

## Received on account, Payout key

Always "00"		<input type="text" value="0"/> <input type="text" value="0"/> D <sub>8</sub> D <sub>7</sub>
High amount limit specification for change amount due. (refer to *1 on the previous page.)	Maximum value (0 ~ 9)	<input type="text"/> <input type="text"/> D <sub>6</sub> D <sub>5</sub>
	Number of zeros (0 ~ 9)	
Always "0000"		<input type="text" value="0"/> ~ <input type="text" value="0"/> D <sub>4</sub> ~ D <sub>1</sub>

## Minus key

Always "00"		<input type="text" value="0"/> <input type="text" value="0"/> D <sub>8</sub> D <sub>7</sub>
Allow credit balance.	No = 0 Yes = 1	<input type="text"/> D <sub>6</sub>
High digit limit specification	Significant number	<input type="text"/> D <sub>5</sub>
Taxable status 1	a No = 0 Yes = 1	a+b+c = <input type="text"/> D <sub>4</sub>
Taxable status 2	b No = 0 Yes = 2	
Taxable status 3	c No = 0 Yes = 4	
Taxable status 4	No = 0 Yes = 4	<input type="text"/> D <sub>3</sub>
Always "00"		<input type="text" value="0"/> <input type="text" value="0"/> D <sub>2</sub> D <sub>1</sub>

## #/No sale key

Always "00"		<input type="text" value="0"/> <input type="text" value="0"/> D <sub>8</sub> D <sub>7</sub>
Treat as the first transaction.	No = 0 Yes = 1	<input type="text"/> D <sub>6</sub>
Always "00000"		<input type="text" value="0"/> ~ <input type="text" value="0"/> D <sub>5</sub> ~ D <sub>1</sub>

## Discount key and premium key

Always "0"		<input type="text" value="0"/> D <sub>8</sub>
Fraction control, round off = 0, cut off = 1, round up = 2	Significant number	<input type="text"/> D <sub>7</sub>
Prohibit manual entry to override programmed percentage.	No = 0 Yes = 2	<input type="text"/> D <sub>6</sub>
Always "0"		<input type="text" value="0"/> D <sub>5</sub>
Taxable status 1	a No = 0 Yes = 1	a+b+c = <input type="text"/> D <sub>4</sub>
Taxable status 2	b No = 0 Yes = 2	
Taxable status 3	c No = 0 Yes = 4	
Taxable status 4	No = 0 Yes = 4	<input type="text"/> D <sub>3</sub>
Always "00"		<input type="text" value="0"/> <input type="text" value="0"/> D <sub>2</sub> D <sub>1</sub>

# Calculator functions

While registering at the REG mode, you can switch to CAL mode and then return to REG mode to resume the registration.

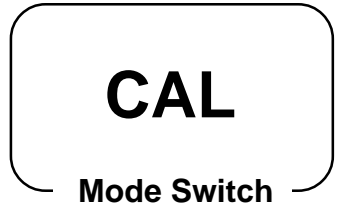

## Example 1 (Calculation examples)

	OPERATION	DISPLAY
Clear		0
5+3-2=		6
(23-56)×78=		-2574
12 % on 1500		180

## Example 2 (Memory recall)

Item 1	Unit price	\$10.00
	Quantity	1
	Dept.	1
Item 2	Unit price	\$20.00
	Quantity	1
	Dept.	2
Payment	Cash	\$10.00
	by 3 persons each,	

OPERATION	DISPLAY/RECEIPT
<p><b>Turn to REG</b></p>	
<p><b>Turn to CAL</b></p>	
<p>Memory recall: Recalls subtotal amount</p> <p>Divides the subtotal by 3 persons</p>	
<p><b>Turn to REG</b></p>	
<p>Memory recall: Recalls the result amount</p>	

# Convenient Operations and Setups

## Programming calculator mode control

Open drawer when $\boxed{\text{CA/AMT}=\text{TEND}}$ (equal) is pressed in CAL mode.	a	No = 0 Yes = 1	a+b+c = <input type="text"/> D <sub>5</sub>
Open drawer when $\boxed{\#/\text{NS}}$ is pressed in CAL mode.	b	No = 0 Yes = 2	
Print calculator total on the daily report.	c	Yes = 0 No = 4	
Always "0000"			<input type="text"/> 0 ~ <input type="text"/> 0 D <sub>4</sub> ~ D <sub>1</sub>

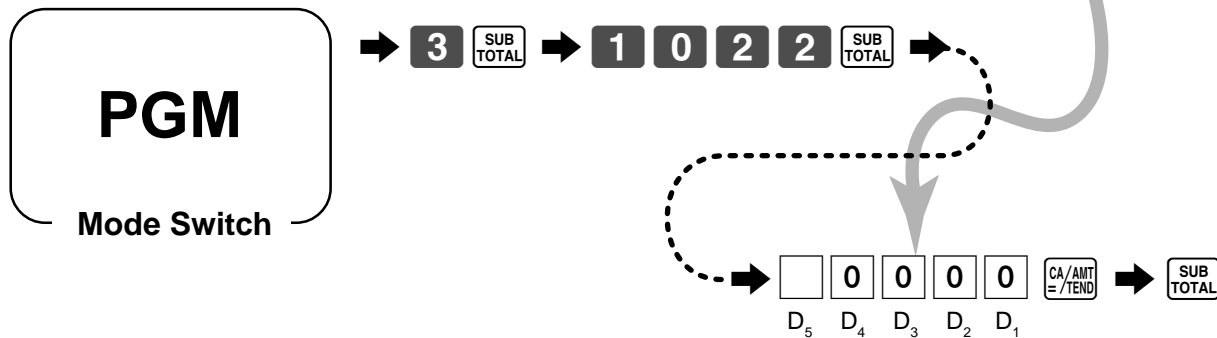

## About the daylight saving time

It is possible to set the internal clock forward/backward by 1 ~ 9 hour(s) for the daylight saving time.

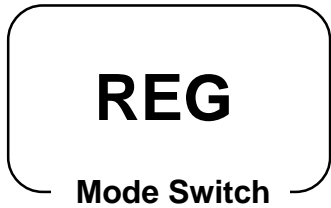

OPERATION	DISPLAY
<ul style="list-style-type: none"> <li>• Forward by 1 hour</li> </ul>	<div style="display: flex; align-items: center;"> <div style="margin-right: 10px;"> <math>\boxed{\text{DATE TIME}}</math> * <b>1</b> <math>\boxed{\text{DATE TIME}}</math> <b>C</b> </div> <div style="border: 1px solid black; padding: 5px; width: 150px;">12-34</div> <div style="margin-left: 10px;">(Blinking)</div> </div> <div style="display: flex; align-items: center; margin-top: 5px;"> <div style="margin-right: 10px;"><math>\boxed{\text{DATE TIME}}</math></div> <div style="border: 1px solid black; padding: 5px; width: 150px;">13-34</div> <div style="margin-left: 10px;">Set forward by 1 hour.</div> </div>
<ul style="list-style-type: none"> <li>• Backward by 1 hour</li> </ul>	<div style="display: flex; align-items: center;"> <div style="margin-right: 10px;"> <math>\boxed{\text{DATE TIME}}</math> * <b>1</b> <math>\boxed{\text{DATE TIME}}</math> <b>C</b> </div> <div style="border: 1px solid black; padding: 5px; width: 150px;">12-34</div> <div style="margin-left: 10px;">(Blinking)</div> </div> <div style="display: flex; align-items: center; margin-top: 5px;"> <div style="margin-right: 10px;"><math>\boxed{\text{DATE TIME}}</math></div> <div style="border: 1px solid black; padding: 5px; width: 150px;">12-34</div> <div style="margin-left: 10px;">(Blinking)</div> </div> <div style="display: flex; align-items: center; margin-top: 5px;"> <div style="margin-right: 10px;"><math>\boxed{\text{DATE TIME}}</math></div> <div style="border: 1px solid black; padding: 5px; width: 150px;">11-34</div> <div style="margin-left: 10px;">Set backward by 1 hour.</div> </div>

\* Put 2 ~ 9, in case of set the clock by 2 ~ 9 hours.

# Printing read/reset reports

- **Read report**

You can print read reports at any time during the business day without affecting the data stored in the cash register's memory.

- **Reset report**

You should print reset reports at the end of the business day.

### Important!

- The reset operation issues a report and also clears all sales data from the cash register's memory.
- Be sure to perform the reset operations at the end of each business day. Otherwise, you will not be able to distinguish between the sales data for different dates.

## To print the individual department, PLU/subdepartment read report

This report shows sales for specific departments or PLU/subdepartments.

OPERATION	REPORT																																																								
<div style="border: 1px solid black; border-radius: 15px; padding: 10px; width: fit-content; margin: 0 auto;"> <p><b>X mode</b></p> <p>Mode Switch</p> </div>																																																									
<p>• Specifying a department</p> <p>+ 1, - 2, × 3, ÷ 4, ~ 24</p>																																																									
<p>• Specifying a PLU</p> <p>1 ~ 1 5 00 PLU</p>																																																									
<p>SUB TOTAL</p>																																																									
	<table border="1"> <tbody> <tr> <td>X</td> <td>15-03-2002</td> <td>17:05</td> <td>Read mode/date/time</td> </tr> <tr> <td>CLERK</td> <td>01</td> <td>000250</td> <td>Clerk/consecutive No.</td> </tr> <tr> <td></td> <td></td> <td>X</td> <td>Read symbol</td> </tr> <tr> <td>DEPT01</td> <td>QT</td> <td>15</td> <td>Department descriptor/No. of items</td> </tr> <tr> <td>29.6%</td> <td></td> <td>.339.50</td> <td>Sales ratio/department amount</td> </tr> <tr> <td>DEPT02</td> <td>QT</td> <td>19</td> <td></td> </tr> <tr> <td>5.46%</td> <td></td> <td>.62.70</td> <td></td> </tr> <tr> <td>PLU0001</td> <td>QT</td> <td>31</td> <td>PLU descriptor/No. of items</td> </tr> <tr> <td>12.12%</td> <td></td> <td>.139.10</td> <td>Sales ratio/PLU amount</td> </tr> <tr> <td>PLU0002</td> <td>QT</td> <td>23</td> <td></td> </tr> <tr> <td>29%</td> <td></td> <td>.332.67</td> <td></td> </tr> <tr> <td colspan="3">-----</td> <td></td> </tr> <tr> <td>TOTAL</td> <td>QT</td> <td>88</td> <td>Total No. of items</td> </tr> <tr> <td>76.1%</td> <td></td> <td>.873.97</td> <td>Total amount</td> </tr> </tbody> </table>	X	15-03-2002	17:05	Read mode/date/time	CLERK	01	000250	Clerk/consecutive No.			X	Read symbol	DEPT01	QT	15	Department descriptor/No. of items	29.6%		.339.50	Sales ratio/department amount	DEPT02	QT	19		5.46%		.62.70		PLU0001	QT	31	PLU descriptor/No. of items	12.12%		.139.10	Sales ratio/PLU amount	PLU0002	QT	23		29%		.332.67		-----				TOTAL	QT	88	Total No. of items	76.1%		.873.97	Total amount
X	15-03-2002	17:05	Read mode/date/time																																																						
CLERK	01	000250	Clerk/consecutive No.																																																						
		X	Read symbol																																																						
DEPT01	QT	15	Department descriptor/No. of items																																																						
29.6%		.339.50	Sales ratio/department amount																																																						
DEPT02	QT	19																																																							
5.46%		.62.70																																																							
PLU0001	QT	31	PLU descriptor/No. of items																																																						
12.12%		.139.10	Sales ratio/PLU amount																																																						
PLU0002	QT	23																																																							
29%		.332.67																																																							
-----																																																									
TOTAL	QT	88	Total No. of items																																																						
76.1%		.873.97	Total amount																																																						

After you finish to select departments, PLU/subdepartments, press **SUB TOTAL** to terminate.

# Convenient Operations and Setups

## To print the financial read report

This report shows gross sales, net sales, cash in drawer and check in drawer.

OPERATION	REPORT																																																												
<div style="border: 1px solid black; border-radius: 15px; padding: 10px; text-align: center; margin-bottom: 10px;"> <h3 style="margin: 0;">X mode</h3> </div> <p style="text-align: center; margin: 0;"><b>Mode Switch</b></p> <p style="text-align: center; margin: 5px 0;">↓</p> <p style="margin: 0;">Money declaration *1</p> <p style="margin: 0;">(Cash in drawer amount <span style="border: 1px solid black; padding: 2px;"># / NS</span>)</p> <p style="text-align: center; margin: 5px 0;">↓</p> <div style="border: 1px solid black; padding: 2px; text-align: center; width: fit-content; margin: 0 auto;"> <span style="font-size: 0.8em;">X / DATE</span>  <span style="font-size: 0.8em;">TIME</span> </div>	<table border="1" style="width: 100%; border-collapse: collapse; font-family: monospace;"> <tr> <td style="width: 15%;">X</td> <td style="width: 25%;">15-03-2002</td> <td style="width: 15%;">17:10</td> <td style="width: 10%;"></td> <td style="width: 35%;">Read mode/date/time</td> </tr> <tr> <td>CLERK</td> <td>01</td> <td></td> <td>000251</td> <td>Clerk/consecutive No.</td> </tr> <tr> <td></td> <td style="text-align: center;"><b>FLASH</b></td> <td></td> <td style="text-align: center;">X</td> <td>Report title/read symbol</td> </tr> <tr> <td>GROSS TOTAL</td> <td>QT</td> <td>1216</td> <td></td> <td>Gross No. of items</td> </tr> <tr> <td></td> <td></td> <td></td> <td>·21954.50</td> <td>Gross amount</td> </tr> <tr> <td>NET TOTAL</td> <td>No</td> <td>523</td> <td></td> <td>Net No. of customers</td> </tr> <tr> <td></td> <td></td> <td></td> <td>·27733.12</td> <td>Net amount</td> </tr> <tr> <td>CASH-INDW</td> <td></td> <td></td> <td>·27289.10</td> <td>Cash in drawer (b)</td> </tr> <tr> <td>#</td> <td></td> <td></td> <td>·27270.00</td> <td>Declared amount (a)</td> </tr> <tr> <td></td> <td></td> <td></td> <td>·19.10</td> <td>Difference (b) - (a)</td> </tr> <tr> <td>CHARGE-INDW</td> <td></td> <td></td> <td>·398.00</td> <td>Charge in drawer</td> </tr> <tr> <td>CHECK-INDW</td> <td></td> <td></td> <td>·332.67</td> <td>Check in drawer</td> </tr> </table>	X	15-03-2002	17:10		Read mode/date/time	CLERK	01		000251	Clerk/consecutive No.		<b>FLASH</b>		X	Report title/read symbol	GROSS TOTAL	QT	1216		Gross No. of items				·21954.50	Gross amount	NET TOTAL	No	523		Net No. of customers				·27733.12	Net amount	CASH-INDW			·27289.10	Cash in drawer (b)	#			·27270.00	Declared amount (a)				·19.10	Difference (b) - (a)	CHARGE-INDW			·398.00	Charge in drawer	CHECK-INDW			·332.67	Check in drawer
X	15-03-2002	17:10		Read mode/date/time																																																									
CLERK	01		000251	Clerk/consecutive No.																																																									
	<b>FLASH</b>		X	Report title/read symbol																																																									
GROSS TOTAL	QT	1216		Gross No. of items																																																									
			·21954.50	Gross amount																																																									
NET TOTAL	No	523		Net No. of customers																																																									
			·27733.12	Net amount																																																									
CASH-INDW			·27289.10	Cash in drawer (b)																																																									
#			·27270.00	Declared amount (a)																																																									
			·19.10	Difference (b) - (a)																																																									
CHARGE-INDW			·398.00	Charge in drawer																																																									
CHECK-INDW			·332.67	Check in drawer																																																									

\*1 Money declaration:

Count how much cash is in the drawer and input this amount (up to 8-digits).

The cash register will automatically compare the input with the cash in drawer in the memory and print the difference between these two amounts.

Note that if money declaration is required by programming (page 45), you cannot skip this procedure.

## To print the group read report

This report shows group totals.

OPERATION	REPORT																																																																																															
<div style="border: 1px solid black; border-radius: 15px; padding: 10px; text-align: center; margin-bottom: 10px;"> <h3 style="margin: 0;">X mode</h3> </div> <p style="text-align: center; margin: 0;"><b>Mode Switch</b></p> <p style="text-align: center; margin: 5px 0;">↓</p> <div style="display: flex; justify-content: center; align-items: center; gap: 5px;"> <div style="border: 1px solid black; padding: 2px; text-align: center; width: 20px;">6</div> <div style="border: 1px solid black; padding: 2px; text-align: center; font-size: 0.8em;">CA/AMT =/TEND</div> </div>	<table border="1" style="width: 100%; border-collapse: collapse; font-family: monospace;"> <tr> <td style="width: 15%;">X</td> <td style="width: 25%;">15-03-2002</td> <td style="width: 15%;">17:15</td> <td style="width: 10%;"></td> <td style="width: 35%;">Read mode/date/time</td> </tr> <tr> <td>CLERK</td> <td>01</td> <td></td> <td>000252</td> <td>Clerk/consecutive No.</td> </tr> <tr> <td></td> <td style="text-align: center;"><b>0006 GROUP</b></td> <td></td> <td style="text-align: center;">X</td> <td>Report code/report title/read symbol</td> </tr> <tr> <td><b>01</b> .....</td> <td>QT</td> <td>16</td> <td></td> <td>Group 01/No. of items</td> </tr> <tr> <td></td> <td></td> <td></td> <td>·54.50</td> <td>Sales ratio/group 01 amount</td> </tr> <tr> <td></td> <td></td> <td></td> <td>0.24%</td> <td></td> </tr> <tr> <td><b>02</b> .....</td> <td>QT</td> <td>25</td> <td></td> <td></td> </tr> <tr> <td></td> <td></td> <td></td> <td>·21.33</td> <td></td> </tr> <tr> <td></td> <td></td> <td></td> <td>0.09%</td> <td></td> </tr> <tr> <td><b>03</b> .....</td> <td>QT</td> <td>132</td> <td></td> <td></td> </tr> <tr> <td></td> <td></td> <td></td> <td>·90.78</td> <td></td> </tr> <tr> <td></td> <td></td> <td></td> <td>0.12%</td> <td></td> </tr> <tr> <td>.....</td> <td>QT</td> <td>6</td> <td></td> <td>Total of non-group link departments</td> </tr> <tr> <td></td> <td></td> <td></td> <td>·4.50</td> <td></td> </tr> <tr> <td></td> <td></td> <td></td> <td>0.02%</td> <td></td> </tr> <tr> <td colspan="4" style="border-top: 1px dashed black;">TOTAL</td> <td></td> </tr> <tr> <td></td> <td>QT</td> <td>156</td> <td></td> <td>Total No. of items</td> </tr> <tr> <td></td> <td></td> <td></td> <td>·332.67</td> <td>Total amount</td> </tr> <tr> <td></td> <td></td> <td></td> <td>0.47%</td> <td></td> </tr> </table>	X	15-03-2002	17:15		Read mode/date/time	CLERK	01		000252	Clerk/consecutive No.		<b>0006 GROUP</b>		X	Report code/report title/read symbol	<b>01</b> .....	QT	16		Group 01/No. of items				·54.50	Sales ratio/group 01 amount				0.24%		<b>02</b> .....	QT	25						·21.33					0.09%		<b>03</b> .....	QT	132						·90.78					0.12%		.....	QT	6		Total of non-group link departments				·4.50					0.02%		TOTAL						QT	156		Total No. of items				·332.67	Total amount				0.47%	
X	15-03-2002	17:15		Read mode/date/time																																																																																												
CLERK	01		000252	Clerk/consecutive No.																																																																																												
	<b>0006 GROUP</b>		X	Report code/report title/read symbol																																																																																												
<b>01</b> .....	QT	16		Group 01/No. of items																																																																																												
			·54.50	Sales ratio/group 01 amount																																																																																												
			0.24%																																																																																													
<b>02</b> .....	QT	25																																																																																														
			·21.33																																																																																													
			0.09%																																																																																													
<b>03</b> .....	QT	132																																																																																														
			·90.78																																																																																													
			0.12%																																																																																													
.....	QT	6		Total of non-group link departments																																																																																												
			·4.50																																																																																													
			0.02%																																																																																													
TOTAL																																																																																																
	QT	156		Total No. of items																																																																																												
			·332.67	Total amount																																																																																												
			0.47%																																																																																													

Issue this report before the daily sales reset report, otherwise the group totals are all reset.

## To print the PLU/subdepartment read/reset report

This report shows sales for PLUs/subdepartments.

OPERATION		REPORT																																																									
<p><b>Read: X mode</b> <b>Reset: Z mode</b></p> <p>Mode Switch</p> <p><b>1</b> <small>CA/AMT =/TEND</small></p>		<table border="1"> <tr> <td>Z</td> <td>15-03-2002</td> <td>17:25</td> <td>Reset mode/date/time</td> </tr> <tr> <td>CLERK</td> <td>01</td> <td>000254</td> <td>Clerk/consecutive No.</td> </tr> <tr> <td>0001</td> <td>PLU</td> <td>Z 0001</td> <td>Report code/report title/reset symbol/reset counter</td> </tr> <tr> <td>PLU0001</td> <td>QT</td> <td>16</td> <td>PLU0001/No. of items</td> </tr> <tr> <td>0.24%</td> <td></td> <td>.54.50</td> <td>Sales ratio/PLU0001 amount</td> </tr> <tr> <td>PLU0002</td> <td>QT</td> <td>25</td> <td></td> </tr> <tr> <td>0.09%</td> <td></td> <td>.21.33</td> <td></td> </tr> <tr> <td>PLU0003</td> <td>QT</td> <td>132</td> <td></td> </tr> <tr> <td>0.12%</td> <td></td> <td>.90.78</td> <td></td> </tr> <tr> <td>PLU0400</td> <td>QT</td> <td>8</td> <td></td> </tr> <tr> <td>0.02%</td> <td></td> <td>.4.50</td> <td></td> </tr> <tr> <td colspan="4">-----</td> </tr> <tr> <td>TOTAL</td> <td>QT</td> <td>156</td> <td>Total No. of items</td> </tr> <tr> <td>100%</td> <td></td> <td>.21960.90</td> <td>Total amount</td> </tr> </table>		Z	15-03-2002	17:25	Reset mode/date/time	CLERK	01	000254	Clerk/consecutive No.	0001	PLU	Z 0001	Report code/report title/reset symbol/reset counter	PLU0001	QT	16	PLU0001/No. of items	0.24%		.54.50	Sales ratio/PLU0001 amount	PLU0002	QT	25		0.09%		.21.33		PLU0003	QT	132		0.12%		.90.78		PLU0400	QT	8		0.02%		.4.50		-----				TOTAL	QT	156	Total No. of items	100%		.21960.90	Total amount
Z	15-03-2002	17:25	Reset mode/date/time																																																								
CLERK	01	000254	Clerk/consecutive No.																																																								
0001	PLU	Z 0001	Report code/report title/reset symbol/reset counter																																																								
PLU0001	QT	16	PLU0001/No. of items																																																								
0.24%		.54.50	Sales ratio/PLU0001 amount																																																								
PLU0002	QT	25																																																									
0.09%		.21.33																																																									
PLU0003	QT	132																																																									
0.12%		.90.78																																																									
PLU0400	QT	8																																																									
0.02%		.4.50																																																									
-----																																																											
TOTAL	QT	156	Total No. of items																																																								
100%		.21960.90	Total amount																																																								

## To print the hourly sales read/reset report

This report shows hourly breakdowns of sales.

OPERATION		REPORT																																																									
<p><b>Read: X mode</b> <b>Reset: Z mode</b></p> <p>Mode Switch</p> <p><b>2</b> <small>CA/AMT =/TEND</small></p>		<table border="1"> <tr> <td>Z</td> <td>15-03-2002</td> <td>17:30</td> <td>Reset mode/date/time</td> </tr> <tr> <td>CLERK</td> <td>01</td> <td>000255</td> <td>Clerk/consecutive No.</td> </tr> <tr> <td>0002</td> <td>HOURLY</td> <td>Z 0001</td> <td>Report code/report title/reset symbol/reset counter</td> </tr> <tr> <td>00:00-01:00</td> <td>No</td> <td>6</td> <td>Time range/No. of customers</td> </tr> <tr> <td></td> <td></td> <td>.4.50</td> <td>Sales amount</td> </tr> <tr> <td>01:00-02:00</td> <td>No</td> <td>25</td> <td></td> </tr> <tr> <td></td> <td></td> <td>.21.33</td> <td></td> </tr> <tr> <td>02:00-03:00</td> <td>No</td> <td>132</td> <td></td> </tr> <tr> <td></td> <td></td> <td>.90.78</td> <td></td> </tr> <tr> <td>23:00-24:00</td> <td>No</td> <td>1</td> <td></td> </tr> <tr> <td></td> <td></td> <td>.1.50</td> <td></td> </tr> <tr> <td colspan="4">-----</td> </tr> <tr> <td>TOTAL</td> <td>No</td> <td>56</td> <td>Total No. of customers</td> </tr> <tr> <td></td> <td></td> <td>.1338.40</td> <td>Total amount</td> </tr> </table>		Z	15-03-2002	17:30	Reset mode/date/time	CLERK	01	000255	Clerk/consecutive No.	0002	HOURLY	Z 0001	Report code/report title/reset symbol/reset counter	00:00-01:00	No	6	Time range/No. of customers			.4.50	Sales amount	01:00-02:00	No	25				.21.33		02:00-03:00	No	132				.90.78		23:00-24:00	No	1				.1.50		-----				TOTAL	No	56	Total No. of customers			.1338.40	Total amount
Z	15-03-2002	17:30	Reset mode/date/time																																																								
CLERK	01	000255	Clerk/consecutive No.																																																								
0002	HOURLY	Z 0001	Report code/report title/reset symbol/reset counter																																																								
00:00-01:00	No	6	Time range/No. of customers																																																								
		.4.50	Sales amount																																																								
01:00-02:00	No	25																																																									
		.21.33																																																									
02:00-03:00	No	132																																																									
		.90.78																																																									
23:00-24:00	No	1																																																									
		.1.50																																																									
-----																																																											
TOTAL	No	56	Total No. of customers																																																								
		.1338.40	Total amount																																																								

# Convenient Operations and Setups

## To print the monthly sales read/reset report

This report shows monthly breakdowns of sales.

### OPERATION

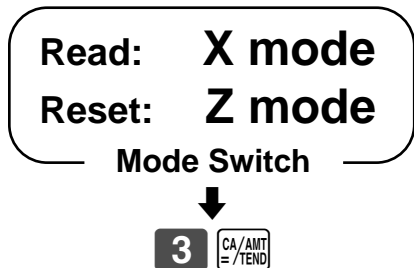

### REPORT

Z	15-03-2002 17:35			Reset mode/date/time
CLERK 01		000256		Clerk/consecutive No.
0003 MONTHLY		Z 0001		Report code/report title/reset symbol/reset counter
1 . . . .	No	6		Date of a month/No. of customers
2 . . . .	No	4.50		Sales amount
3 . . . .	No	21.33		
		132		
		90.78		
31 . . . .	No	1		
		1.50		
TOTAL	No	56		Total No. of customers
		1338.40		Total amount

## To print the daily sales read/reset report

This report shows sales except for PLUs.

OPERATION	REPORT																																																																																																																																																
<div style="border: 1px solid black; border-radius: 15px; padding: 10px; width: fit-content; margin: 0 auto;"> <p><b>Read: X mode</b> <b>Reset: Z mode</b></p> <p style="text-align: center;"><b>Mode Switch</b></p> <p style="text-align: center;">↓</p> <p>Money declaration *1 (Cash in drawer amount <span style="border: 1px solid black; padding: 2px;"># / NS</span>)</p> <p style="text-align: center;">↓</p> <div style="border: 1px solid black; padding: 2px; display: inline-block;">CA/AMT =/TEND</div> </div>	<table border="1" style="width: 100%; border-collapse: collapse;"> <tr><td>TAX-AMT 1</td><td style="text-align: right;">·732.56</td><td>Taxable amount 1 *3</td></tr> <tr><td>TAX 1</td><td style="text-align: right;">·43.96</td><td>Tax amount 1 *3</td></tr> <tr><td>TAX-AMT 2</td><td style="text-align: right;">·409.72</td><td>Taxable amount 2 *3</td></tr> <tr><td>TAX 2</td><td style="text-align: right;">·21.55</td><td>Tax amount 2 *3</td></tr> <tr><td>TAX-AMT 3</td><td style="text-align: right;">·272.50</td><td>Taxable amount 3 *3</td></tr> <tr><td>TAX 3</td><td style="text-align: right;">·8.18</td><td>Tax amount 3 *3</td></tr> <tr><td>TAX-AMT 4</td><td style="text-align: right;">·5.50</td><td>Taxable amount 4 *3</td></tr> <tr><td>TAX 4</td><td style="text-align: right;">·0.06</td><td>Tax amount 4 *3</td></tr> <tr><td>TAX</td><td style="text-align: right;">·73.75</td><td>Tax total *4</td></tr> <tr><td>ROUNDING AMT</td><td style="text-align: right;">·4.75</td><td>Rounding amount (Australia only)</td></tr> <tr><td>CANCEL TTL</td><td style="text-align: right;">No 2</td><td>Cancellation count</td></tr> <tr><td></td><td style="text-align: right;">·108.52</td><td>Cancellation amount</td></tr> <tr><td>RF-MODE TTL</td><td style="text-align: right;">No 2</td><td>Refund mode operation count *4</td></tr> <tr><td></td><td style="text-align: right;">·3.74</td><td>Refund mode operation amount *4</td></tr> <tr><td>CALCULATOR</td><td style="text-align: right;">No 10</td><td>CAL mode operation count</td></tr> <tr><td colspan="3">-----</td></tr> <tr><td>CASH</td><td style="text-align: right;">No 81</td><td>Cash sales count</td></tr> <tr><td></td><td style="text-align: right;">·836.86</td><td>Cash sales amount</td></tr> <tr><td>CHARGE</td><td style="text-align: right;">No 10</td><td>Charge sales count</td></tr> <tr><td></td><td style="text-align: right;">·197.17</td><td>Charge sales amount</td></tr> <tr><td>CHECK</td><td style="text-align: right;">No 9</td><td>Check sales count</td></tr> <tr><td></td><td style="text-align: right;">·183.60</td><td>Check sales amount</td></tr> <tr><td>RC</td><td style="text-align: right;">No 2</td><td>Received on Account count</td></tr> <tr><td></td><td style="text-align: right;">·78.00</td><td>Received on Account amount</td></tr> <tr><td>PD</td><td style="text-align: right;">No 1</td><td>Paid out count</td></tr> <tr><td></td><td style="text-align: right;">·6.80</td><td>Paid out amount</td></tr> <tr><td>-</td><td style="text-align: right;">No 8</td><td>Subtraction count</td></tr> <tr><td></td><td style="text-align: right;">·3.00</td><td>Subtraction amount</td></tr> <tr><td>%-</td><td style="text-align: right;">No 10</td><td>Discount count</td></tr> <tr><td></td><td style="text-align: right;">·4.62</td><td>Discount amount</td></tr> <tr><td>%+</td><td style="text-align: right;">No 1</td><td>Premium count</td></tr> <tr><td></td><td style="text-align: right;">·1.00</td><td>Premium amount</td></tr> <tr><td>REFUND</td><td style="text-align: right;">No 7</td><td>Refund key count *4</td></tr> <tr><td></td><td style="text-align: right;">·27.79</td><td>Refund key amount *4</td></tr> <tr><td>ERR CORR</td><td style="text-align: right;">No 10</td><td>Error correction count</td></tr> <tr><td></td><td style="text-align: right;">·12.76</td><td>Error correction amount</td></tr> <tr><td>#/NS</td><td style="text-align: right;">No 5</td><td>No sale count</td></tr> <tr><td colspan="3">-----</td></tr> <tr><td>CLERK 01</td><td style="text-align: right;">No 12</td><td>Clerk 1/clerk 1 sales count</td></tr> <tr><td></td><td style="text-align: right;">·127.63</td><td>Clerk 1 sales amount</td></tr> <tr><td>*****</td><td></td><td></td></tr> <tr><td>CLERK 02</td><td style="text-align: right;">No 6</td><td>Training clerk</td></tr> <tr><td></td><td style="text-align: right;">·27.63</td><td></td></tr> <tr><td>*****</td><td></td><td></td></tr> <tr><td>CLERK 02</td><td style="text-align: right;">No 24</td><td></td></tr> <tr><td colspan="3">-----</td></tr> <tr><td>GRND TTL</td><td style="text-align: right;">·0000351217.63</td><td>Non-resettable grand-sales total *4</td></tr> <tr><td></td><td style="text-align: right;">000001---}000253</td><td>Consecutive No. range of the day *4</td></tr> </table>	TAX-AMT 1	·732.56	Taxable amount 1 *3	TAX 1	·43.96	Tax amount 1 *3	TAX-AMT 2	·409.72	Taxable amount 2 *3	TAX 2	·21.55	Tax amount 2 *3	TAX-AMT 3	·272.50	Taxable amount 3 *3	TAX 3	·8.18	Tax amount 3 *3	TAX-AMT 4	·5.50	Taxable amount 4 *3	TAX 4	·0.06	Tax amount 4 *3	TAX	·73.75	Tax total *4	ROUNDING AMT	·4.75	Rounding amount (Australia only)	CANCEL TTL	No 2	Cancellation count		·108.52	Cancellation amount	RF-MODE TTL	No 2	Refund mode operation count *4		·3.74	Refund mode operation amount *4	CALCULATOR	No 10	CAL mode operation count	-----			CASH	No 81	Cash sales count		·836.86	Cash sales amount	CHARGE	No 10	Charge sales count		·197.17	Charge sales amount	CHECK	No 9	Check sales count		·183.60	Check sales amount	RC	No 2	Received on Account count		·78.00	Received on Account amount	PD	No 1	Paid out count		·6.80	Paid out amount	-	No 8	Subtraction count		·3.00	Subtraction amount	%-	No 10	Discount count		·4.62	Discount amount	%+	No 1	Premium count		·1.00	Premium amount	REFUND	No 7	Refund key count *4		·27.79	Refund key amount *4	ERR CORR	No 10	Error correction count		·12.76	Error correction amount	#/NS	No 5	No sale count	-----			CLERK 01	No 12	Clerk 1/clerk 1 sales count		·127.63	Clerk 1 sales amount	*****			CLERK 02	No 6	Training clerk		·27.63		*****			CLERK 02	No 24		-----			GRND TTL	·0000351217.63	Non-resettable grand-sales total *4		000001---}000253	Consecutive No. range of the day *4
TAX-AMT 1	·732.56	Taxable amount 1 *3																																																																																																																																															
TAX 1	·43.96	Tax amount 1 *3																																																																																																																																															
TAX-AMT 2	·409.72	Taxable amount 2 *3																																																																																																																																															
TAX 2	·21.55	Tax amount 2 *3																																																																																																																																															
TAX-AMT 3	·272.50	Taxable amount 3 *3																																																																																																																																															
TAX 3	·8.18	Tax amount 3 *3																																																																																																																																															
TAX-AMT 4	·5.50	Taxable amount 4 *3																																																																																																																																															
TAX 4	·0.06	Tax amount 4 *3																																																																																																																																															
TAX	·73.75	Tax total *4																																																																																																																																															
ROUNDING AMT	·4.75	Rounding amount (Australia only)																																																																																																																																															
CANCEL TTL	No 2	Cancellation count																																																																																																																																															
	·108.52	Cancellation amount																																																																																																																																															
RF-MODE TTL	No 2	Refund mode operation count *4																																																																																																																																															
	·3.74	Refund mode operation amount *4																																																																																																																																															
CALCULATOR	No 10	CAL mode operation count																																																																																																																																															
-----																																																																																																																																																	
CASH	No 81	Cash sales count																																																																																																																																															
	·836.86	Cash sales amount																																																																																																																																															
CHARGE	No 10	Charge sales count																																																																																																																																															
	·197.17	Charge sales amount																																																																																																																																															
CHECK	No 9	Check sales count																																																																																																																																															
	·183.60	Check sales amount																																																																																																																																															
RC	No 2	Received on Account count																																																																																																																																															
	·78.00	Received on Account amount																																																																																																																																															
PD	No 1	Paid out count																																																																																																																																															
	·6.80	Paid out amount																																																																																																																																															
-	No 8	Subtraction count																																																																																																																																															
	·3.00	Subtraction amount																																																																																																																																															
%-	No 10	Discount count																																																																																																																																															
	·4.62	Discount amount																																																																																																																																															
%+	No 1	Premium count																																																																																																																																															
	·1.00	Premium amount																																																																																																																																															
REFUND	No 7	Refund key count *4																																																																																																																																															
	·27.79	Refund key amount *4																																																																																																																																															
ERR CORR	No 10	Error correction count																																																																																																																																															
	·12.76	Error correction amount																																																																																																																																															
#/NS	No 5	No sale count																																																																																																																																															
-----																																																																																																																																																	
CLERK 01	No 12	Clerk 1/clerk 1 sales count																																																																																																																																															
	·127.63	Clerk 1 sales amount																																																																																																																																															
*****																																																																																																																																																	
CLERK 02	No 6	Training clerk																																																																																																																																															
	·27.63																																																																																																																																																
*****																																																																																																																																																	
CLERK 02	No 24																																																																																																																																																
-----																																																																																																																																																	
GRND TTL	·0000351217.63	Non-resettable grand-sales total *4																																																																																																																																															
	000001---}000253	Consecutive No. range of the day *4																																																																																																																																															
<table border="1" style="width: 100%; border-collapse: collapse;"> <tr><td>Z 15-03-2002 17:20</td><td>Reset mode/date/time</td></tr> <tr><td>CLERK 01 000258</td><td>Clerk/consecutive No.</td></tr> <tr><td>0000 DAILY Z 0001</td><td>Report code/report title/reset symbol/ reset counter *5</td></tr> <tr><td>DEPT01 QT 1015</td><td>Department descriptor/No. of items *2</td></tr> <tr><td>47.07% ·10339.50</td><td>Sales ratio/department amount *2</td></tr> <tr><td>DEPT02 QT 19</td><td></td></tr> <tr><td>31.87% ·7000.70</td><td></td></tr> <tr><td>DEPT03 QT 31</td><td></td></tr> <tr><td>18.84% ·4139.10</td><td></td></tr> <tr><td>DEPT04 QT 23</td><td></td></tr> <tr><td>1.51% ·332.67</td><td></td></tr> <tr><td>NON-LINK DPT QT 10</td><td>Non-link department No. of items</td></tr> <tr><td>0.43% ·94.90</td><td>Non-link department amount</td></tr> <tr><td colspan="2">-----</td></tr> <tr><td>GROSS TOTAL QT 1253</td><td>Gross No. of items</td></tr> <tr><td>·21960.90</td><td>Gross sales amount</td></tr> <tr><td>NET TOTAL No 545</td><td>No. of customers</td></tr> <tr><td>·30217.63</td><td>Net sales amount</td></tr> <tr><td>CASH-INDW ·29903.06</td><td>Cash in drawer amount (b)</td></tr> <tr><td># ·29903.06</td><td>Declared amount (a)</td></tr> <tr><td>·0.00</td><td>Difference (b) - (a)</td></tr> <tr><td>CHARGE-INDW ·183.60</td><td>Charge in drawer amount</td></tr> <tr><td>CHECK-INDW ·197.17</td><td>Check in drawer amount</td></tr> <tr><td>CE-CASH 1 ¥7,000</td><td>Foreign currency cash in drawer 1</td></tr> <tr><td>CE-CHECK 1 ¥4,000</td><td>Foreign currency check in drawer 1</td></tr> <tr><td>CE-CASH 2 ¥1,500</td><td>Foreign currency cash in drawer 2</td></tr> <tr><td>CE-CHECK 2 ¥1,000</td><td>Foreign currency check in drawer 2</td></tr> </table>	Z 15-03-2002 17:20	Reset mode/date/time	CLERK 01 000258	Clerk/consecutive No.	0000 DAILY Z 0001	Report code/report title/reset symbol/ reset counter *5	DEPT01 QT 1015	Department descriptor/No. of items *2	47.07% ·10339.50	Sales ratio/department amount *2	DEPT02 QT 19		31.87% ·7000.70		DEPT03 QT 31		18.84% ·4139.10		DEPT04 QT 23		1.51% ·332.67		NON-LINK DPT QT 10	Non-link department No. of items	0.43% ·94.90	Non-link department amount	-----		GROSS TOTAL QT 1253	Gross No. of items	·21960.90	Gross sales amount	NET TOTAL No 545	No. of customers	·30217.63	Net sales amount	CASH-INDW ·29903.06	Cash in drawer amount (b)	# ·29903.06	Declared amount (a)	·0.00	Difference (b) - (a)	CHARGE-INDW ·183.60	Charge in drawer amount	CHECK-INDW ·197.17	Check in drawer amount	CE-CASH 1 ¥7,000	Foreign currency cash in drawer 1	CE-CHECK 1 ¥4,000	Foreign currency check in drawer 1	CE-CASH 2 ¥1,500	Foreign currency cash in drawer 2	CE-CHECK 2 ¥1,000	Foreign currency check in drawer 2																																																																																											
Z 15-03-2002 17:20	Reset mode/date/time																																																																																																																																																
CLERK 01 000258	Clerk/consecutive No.																																																																																																																																																
0000 DAILY Z 0001	Report code/report title/reset symbol/ reset counter *5																																																																																																																																																
DEPT01 QT 1015	Department descriptor/No. of items *2																																																																																																																																																
47.07% ·10339.50	Sales ratio/department amount *2																																																																																																																																																
DEPT02 QT 19																																																																																																																																																	
31.87% ·7000.70																																																																																																																																																	
DEPT03 QT 31																																																																																																																																																	
18.84% ·4139.10																																																																																																																																																	
DEPT04 QT 23																																																																																																																																																	
1.51% ·332.67																																																																																																																																																	
NON-LINK DPT QT 10	Non-link department No. of items																																																																																																																																																
0.43% ·94.90	Non-link department amount																																																																																																																																																
-----																																																																																																																																																	
GROSS TOTAL QT 1253	Gross No. of items																																																																																																																																																
·21960.90	Gross sales amount																																																																																																																																																
NET TOTAL No 545	No. of customers																																																																																																																																																
·30217.63	Net sales amount																																																																																																																																																
CASH-INDW ·29903.06	Cash in drawer amount (b)																																																																																																																																																
# ·29903.06	Declared amount (a)																																																																																																																																																
·0.00	Difference (b) - (a)																																																																																																																																																
CHARGE-INDW ·183.60	Charge in drawer amount																																																																																																																																																
CHECK-INDW ·197.17	Check in drawer amount																																																																																																																																																
CE-CASH 1 ¥7,000	Foreign currency cash in drawer 1																																																																																																																																																
CE-CHECK 1 ¥4,000	Foreign currency check in drawer 1																																																																																																																																																
CE-CASH 2 ¥1,500	Foreign currency cash in drawer 2																																																																																																																																																
CE-CHECK 2 ¥1,000	Foreign currency check in drawer 2																																																																																																																																																

\*1 Money declaration:

Count how much cash is in the drawer and input this amount (up to 8-digits).

The cash register will automatically compare the input with the cash in drawer in the memory and print the difference between these two amounts.

Note that if money declaration is required by programming (page 45), you cannot skip this procedure.

\*2 Zero totalled departments (the amount and item numbers are both zero) are not printed.

\*3 Taxable amount and tax amount are printed only if the corresponding tax table is programmed.

\*4 These items can be skipped by programming.

\*5 The “\*” symbol is printed on the reset report, if memory overflow occurred in the totalizer.

# Convenient Operations and Setups

## To print the periodic-1/-2 sales read/reset reports

These reports show sales breakdowns of sales by any two kinds of period you want.

### OPERATION

### REPORT

**Read: X mode**  
**Reset: Z mode**  
**Mode Switch**



- 1 0 0** (Periodic-1 Read)
- 3 0 0** (Periodic-2 Read)
- 2 0 0** (Periodic-1 Reset)
- 4 0 0** (Periodic-2 Reset)



CA/AMT  
= /TEND

Z	15-03-2002	17:40		Reset mode/date/time
CLERK	01	000257		Clerk/consecutive No.
0200	PERIODIC-1	ZZ0001		Report code/report title/reset symbol/ reset counter
DEPT01	QT	1015		Department descriptor/No. of items *1
	47.07%	·10339.50		Sales ratio/department amount *1
DEPT02	QT	19		
	31.87%	·7000.70		
DEPT03	QT	31		
	18.84%	·4139.10		
DEPT04	QT	23		
	1.51%	·332.87		
NON-LINK DPT	QT	10		Non-link department No. of items
	0.43%	·94.90		Non-link department amount
-----				
GROSS TOTAL	QT	1253		Gross No. of items
		·21960.90		Gross sales amount
NET TOTAL	No	545		No. of customers
		·30217.63		Net sales amount
CASH-INDW		·29903.06		Cash in drawer amount
CHARGE-INDW		·183.60		Charge in drawer amount
CHECK-INDW		·197.17		Check in drawer amount
TAX-AMT 1		·732.56		Taxable amount 1 *2
TAX 1		·43.96		Tax amount 1 *2
TAX-AMT 2		·409.72		Taxable amount 2 *2
TAX 2		·21.55		Tax amount 2 *2
TAX-AMT 3		·272.50		Taxable amount 3 *2
TAX 3		·8.18		Tax amount 3 *2
TAX-AMT 4		·5.50		Taxable amount 4 *2
TAX 4		·0.06		Tax amount 4 *2
TAX		·73.75		Tax total *3
ROUNDING AMT		·4.75		Rounding amount (Australia only)
CANCEL TTL	No	2		Cancellation count
		·108.52		Cancellation amount

RF-MODE	TTL	No	2	Refund mode operation count *3
			·3.74	Refund mode operation amount *3
CALCULATOR		No	10	CAL mode operation count
-----				
CASH		No	81	Cash sales count
			·836.86	Cash sales amount
CHARGE		No	10	Charge sales count
			·197.17	Charge sales amount
CHECK		No	9	Check sales count
			·183.60	Check sales amount
RC		No	2	Received on Account count
			·78.00	Received on Account amount
PD		No	1	Paid out count
			·6.80	Paid out amount
-		No	8	Subtraction count
			·3.00	Subtraction amount
%-		No	10	Discount count
			·4.62	Discount amount
%+		No	1	Premium count
			·1.00	Premium amount
REFUND		No	7	Refund key count *3
			·27.79	Refund key amount *3
ERR CORR		No	10	Error correction count
			·12.76	Error correction amount
#/NS		No	5	No sale count
-----				
CLERK 01		No	12	Clerk 1/clerk 1 sales count
			·127.63	Clerk 1 sales amount
*****				
CLERK 02		No	6	Training clerk
			·27.63	
*****				
CLERK 03		No	24	
			·217.63	

\*1 Zero totalled departments (the amount and item numbers are both zero) are not printed.

\*2 Taxable amount and tax amount are printed only if the corresponding tax table is programmed.

\*3 These items can be skipped by programming.

# Reading the cash register's program

To print unit price/rate program (except PLU)

OPERATION	REPORT
<div style="border: 1px solid black; border-radius: 15px; padding: 10px; width: fit-content; margin: 0 auto;"> <p><b>PGM mode</b></p> <p>Mode Switch</p> <p>↓</p> <p><b>1</b> SUB TOTAL</p> <p>↓</p> <p>SUB TOTAL</p> </div>	<pre> PGM1 10-03-2002 09:30 CLERK 01 000010 PGM1..... DEPT01 T1 @1.00 DEPT02 @2.00 DEPT23 @0.00 DEPT24 @0.00 - @0.00 %- 12.34% %+ 10% EXCHG1 105.05 EXCHG2 1.55                     </pre> <p>Mode/date/time Clerk/consecutive No. Program read symbol Dept. descriptor/tax status/unit price *1 Reduction preset amount Discount rate Premium rate Currency exchange 1 rate Currency exchange 2 rate</p>

\*1 Departments without being programmed are not printed on this report.

To print the PLU program

OPERATION	REPORT
<div style="border: 1px solid black; border-radius: 15px; padding: 10px; width: fit-content; margin: 0 auto;"> <p><b>PGM mode</b></p> <p>Mode Switch</p> <p>↓</p> <p><b>6</b> SUB TOTAL</p> <p>↓</p> <p>SUB TOTAL</p> </div>	<pre> PGM6 10-03-2002 09:45 CLERK 01 000013 PGM6..... PLU0001 T1 0001 0000100000 @1.00 PLU0002 0002 0000000000 @2.00 PLU0003 0003 0000000000 @3.00 PLU0004 0004 0000000000 @4.00 PLU0005 0005 0000000000 @5.00 PLU0006 0006 0000000000 @6.00 PLU0007 T2 0007 0000200000 @7.00 PLU0008 0008 0000000000 @8.00 PLU0009 0009 0000000000 @9.00 PLU0010 0010 0000000000 @10.00 PLU0799 T2 0000 0000200000 @799.00 PLU0800 0800 0000000000 @800.00                     </pre> <p>Mode/date/time Clerk/consecutive No. Program read symbol Item character/tax symbol/PLU No. Status program/unit price *1</p>

\*1 PLUs without being programmed are not printed on this report.

# Convenient Operations and Setups

## To print key descriptor, name, message program (except PLU)

OPERATION	REPORT																																																																																																																																		
<div style="border: 1px solid black; border-radius: 15px; padding: 10px; width: fit-content; margin: 0 auto;"> <p style="font-size: 24px; font-weight: bold; margin: 0;">PGM mode</p> <p style="font-weight: bold; margin: 5px 0;">Mode Switch</p> <p style="text-align: center;">↓</p> <div style="display: flex; align-items: center; justify-content: center; gap: 5px;"> <div style="border: 1px solid black; padding: 2px 5px; font-weight: bold; font-size: 18px;">2</div> <div style="border: 1px solid black; padding: 2px 5px; font-size: 10px;">SUB TOTAL</div> </div> <p style="text-align: center;">↓</p> <div style="border: 1px solid black; padding: 2px 5px; font-size: 10px;">SUB TOTAL</div> </div>	<table border="0" style="width: 100%; border-collapse: collapse;"> <tr> <td style="width: 70%; border-right: 1px solid black; padding: 2px;">PGM2 10-03-2002 09:35</td> <td style="padding: 2px;">Mode/date/time</td> </tr> <tr> <td style="border-right: 1px solid black; padding: 2px;">CLERK 01 000011</td> <td style="padding: 2px;">Clerk/consecutive No.</td> </tr> <tr> <td style="border-right: 1px solid black; padding: 2px;">PGM2.....</td> <td style="padding: 2px;">Program read symbol</td> </tr> <tr> <td style="border-right: 1px solid black; padding: 2px;">GROSS TOTAL 01</td> <td style="padding: 2px;">Gross character</td> </tr> <tr> <td style="border-right: 1px solid black; padding: 2px;">NET TOTAL 02</td> <td style="padding: 2px;">Net character</td> </tr> <tr> <td style="border-right: 1px solid black; padding: 2px;">CASH-INDW 03</td> <td style="padding: 2px;">Cash in drawer character</td> </tr> <tr> <td style="border-right: 1px solid black; padding: 2px;">CHARGE-INDW 04</td> <td style="padding: 2px;">Charge in drawer character</td> </tr> <tr> <td style="border-right: 1px solid black; padding: 2px;">CREDIT-INDW 05</td> <td style="padding: 2px;"></td> </tr> <tr> <td style="border-right: 1px solid black; padding: 2px;">CE-CASH 1 07</td> <td style="padding: 2px;">Foreign currency cash 1 character</td> </tr> <tr> <td style="border-right: 1px solid black; padding: 2px;">CE-CHECK 1 08</td> <td style="padding: 2px;">Foreign currency check 1 character</td> </tr> <tr> <td style="border-right: 1px solid black; padding: 2px;">CE-CHECK 2 09</td> <td style="padding: 2px;"></td> </tr> <tr> <td style="border-right: 1px solid black; padding: 2px;">TAX-AMT 1 11</td> <td style="padding: 2px;">Taxable amount 1 character</td> </tr> <tr> <td style="border-right: 1px solid black; padding: 2px;">TAX 1 12</td> <td style="padding: 2px;">Tax 1 character</td> </tr> <tr> <td style="border-right: 1px solid black; padding: 2px;">TAX-AMT 2 13</td> <td style="padding: 2px;"></td> </tr> <tr> <td style="border-right: 1px solid black; padding: 2px;">T 14</td> <td style="padding: 2px;"></td> </tr> <tr> <td style="border-right: 1px solid black; padding: 2px;">ROUNDING AMT 22</td> <td style="padding: 2px;">Rounding character</td> </tr> <tr> <td style="border-right: 1px solid black; padding: 2px;">CANCEL TTL 23</td> <td style="padding: 2px;">Cancellation total character</td> </tr> <tr> <td style="border-right: 1px solid black; padding: 2px;">RF-MODE TTL 24</td> <td style="padding: 2px;">Refund mode total character</td> </tr> <tr> <td style="border-right: 1px solid black; padding: 2px;">COMMISSION 25</td> <td style="padding: 2px;"></td> </tr> <tr> <td style="border-right: 1px solid black; padding: 2px;">CALCULATOR 27</td> <td style="padding: 2px;"></td> </tr> <tr> <td style="border-right: 1px solid black; padding: 2px;">NON-LINK DPT 28</td> <td style="padding: 2px;">Non link department character</td> </tr> <tr> <td style="border-right: 1px solid black; padding: 2px;">CASH 01</td> <td style="padding: 2px;">Cash key descriptor</td> </tr> <tr> <td style="border-right: 1px solid black; padding: 2px;">CHECK 05</td> <td style="padding: 2px;">Check key descriptor</td> </tr> <tr> <td style="border-right: 1px solid black; padding: 2px;">PD 06</td> <td style="padding: 2px;">Paid out key descriptor</td> </tr> <tr> <td style="border-right: 1px solid black; padding: 2px;">R ON/OFF 07</td> <td style="padding: 2px;">Receipt on/off key descriptor</td> </tr> <tr> <td style="border-right: 1px solid black; padding: 2px;">TL 09</td> <td style="padding: 2px;"></td> </tr> <tr> <td style="border-right: 1px solid black; padding: 2px;">CHARGE 10</td> <td style="padding: 2px;"></td> </tr> <tr> <td style="border-right: 1px solid black; padding: 2px;">RC 11</td> <td style="padding: 2px;">Received on account key descriptor</td> </tr> <tr> <td style="border-right: 1px solid black; padding: 2px;">VAT 12</td> <td style="padding: 2px;"></td> </tr> <tr> <td style="border-right: 1px solid black; padding: 2px;">FX 43</td> <td style="padding: 2px;"></td> </tr> <tr> <td style="border-right: 1px solid black; padding: 2px;">- 63</td> <td style="padding: 2px;"></td> </tr> <tr> <td style="border-right: 1px solid black; padding: 2px;">PRICE 63</td> <td style="padding: 2px;"></td> </tr> <tr> <td style="border-right: 1px solid black; padding: 2px;">P/G RCT 66</td> <td style="padding: 2px;"></td> </tr> <tr> <td style="border-right: 1px solid black; padding: 2px;">%+ 67</td> <td style="padding: 2px;"></td> </tr> <tr> <td style="border-right: 1px solid black; padding: 2px;">%- 68</td> <td style="padding: 2px;"></td> </tr> <tr> <td style="border-right: 1px solid black; padding: 2px;">OPEN 69</td> <td style="padding: 2px;"></td> </tr> <tr> <td style="border-right: 1px solid black; padding: 2px;">DEPT01 01</td> <td style="padding: 2px;">Department 1 key character</td> </tr> <tr> <td style="border-right: 1px solid black; padding: 2px;">DEPT02 02</td> <td style="padding: 2px;">Department 2 key character</td> </tr> <tr> <td style="border-right: 1px solid black; padding: 2px;">DEPT23 03</td> <td style="padding: 2px;"></td> </tr> <tr> <td style="border-right: 1px solid black; padding: 2px;">DEPT24 24</td> <td style="padding: 2px;">Department 24 key character</td> </tr> <tr> <td style="border-right: 1px solid black; padding: 2px;">CLERK 01 01</td> <td style="padding: 2px;">Clerk 01 character</td> </tr> <tr> <td style="border-right: 1px solid black; padding: 2px;">CLERK 02 02</td> <td style="padding: 2px;">Clerk 02 character</td> </tr> <tr> <td style="border-right: 1px solid black; padding: 2px;">CLERK 03 03</td> <td style="padding: 2px;"></td> </tr> <tr> <td style="border-right: 1px solid black; padding: 2px;">CLERK 14 14</td> <td style="padding: 2px;"></td> </tr> <tr> <td style="border-right: 1px solid black; padding: 2px;">CLERK 15 15</td> <td style="padding: 2px;">Clerk 15 character</td> </tr> <tr> <td style="border-right: 1px solid black; padding: 2px;">GRND TTL 01</td> <td style="padding: 2px;">Grand total character</td> </tr> <tr> <td style="border-right: 1px solid black; padding: 2px;">. @NoQT 01</td> <td style="padding: 2px;"></td> </tr> <tr> <td style="border-right: 1px solid black; padding: 2px;">NoCT 02</td> <td style="padding: 2px;"></td> </tr> <tr> <td style="border-right: 1px solid black; padding: 2px;">X / 03</td> <td style="padding: 2px;"></td> </tr> <tr> <td style="border-right: 1px solid black; padding: 2px;">T1T2T3T4 04</td> <td style="padding: 2px;">Special character</td> </tr> <tr> <td style="border-right: 1px solid black; padding: 2px;">05</td> <td style="padding: 2px;"></td> </tr> <tr> <td style="border-right: 1px solid black; padding: 2px;">06</td> <td style="padding: 2px;"></td> </tr> <tr> <td style="border-right: 1px solid black; padding: 2px;">07</td> <td style="padding: 2px;"></td> </tr> <tr> <td style="border-right: 1px solid black; padding: 2px;">DAILY 01</td> <td style="padding: 2px;"></td> </tr> <tr> <td style="border-right: 1px solid black; padding: 2px;">PLU 02</td> <td style="padding: 2px;"></td> </tr> <tr> <td style="border-right: 1px solid black; padding: 2px;">HOURLY 03</td> <td style="padding: 2px;"></td> </tr> <tr> <td style="border-right: 1px solid black; padding: 2px;">PERIODIC 04</td> <td style="padding: 2px;">Report header</td> </tr> <tr> <td style="border-right: 1px solid black; padding: 2px;">10</td> <td style="padding: 2px;"></td> </tr> <tr> <td style="border-right: 1px solid black; padding: 2px;">11</td> <td style="padding: 2px;"></td> </tr> <tr> <td style="border-right: 1px solid black; padding: 2px;">E-JOURNAL 12</td> <td style="padding: 2px;"></td> </tr> <tr> <td style="border-right: 1px solid black; padding: 2px;">01</td> <td style="padding: 2px;"></td> </tr> <tr> <td style="border-right: 1px solid black; padding: 2px;">02</td> <td style="padding: 2px;"></td> </tr> <tr> <td style="border-right: 1px solid black; padding: 2px;">* INDICATE RECEIPT 02</td> <td style="padding: 2px;">Receipt message</td> </tr> <tr> <td style="border-right: 1px solid black; padding: 2px;">19</td> <td style="padding: 2px;"></td> </tr> <tr> <td style="border-right: 1px solid black; padding: 2px;">TAXABLE SUPPLY</td> <td style="padding: 2px;"></td> </tr> </table>	PGM2 10-03-2002 09:35	Mode/date/time	CLERK 01 000011	Clerk/consecutive No.	PGM2.....	Program read symbol	GROSS TOTAL 01	Gross character	NET TOTAL 02	Net character	CASH-INDW 03	Cash in drawer character	CHARGE-INDW 04	Charge in drawer character	CREDIT-INDW 05		CE-CASH 1 07	Foreign currency cash 1 character	CE-CHECK 1 08	Foreign currency check 1 character	CE-CHECK 2 09		TAX-AMT 1 11	Taxable amount 1 character	TAX 1 12	Tax 1 character	TAX-AMT 2 13		T 14		ROUNDING AMT 22	Rounding character	CANCEL TTL 23	Cancellation total character	RF-MODE TTL 24	Refund mode total character	COMMISSION 25		CALCULATOR 27		NON-LINK DPT 28	Non link department character	CASH 01	Cash key descriptor	CHECK 05	Check key descriptor	PD 06	Paid out key descriptor	R ON/OFF 07	Receipt on/off key descriptor	TL 09		CHARGE 10		RC 11	Received on account key descriptor	VAT 12		FX 43		- 63		PRICE 63		P/G RCT 66		%+ 67		%- 68		OPEN 69		DEPT01 01	Department 1 key character	DEPT02 02	Department 2 key character	DEPT23 03		DEPT24 24	Department 24 key character	CLERK 01 01	Clerk 01 character	CLERK 02 02	Clerk 02 character	CLERK 03 03		CLERK 14 14		CLERK 15 15	Clerk 15 character	GRND TTL 01	Grand total character	. @NoQT 01		NoCT 02		X / 03		T1T2T3T4 04	Special character	05		06		07		DAILY 01		PLU 02		HOURLY 03		PERIODIC 04	Report header	10		11		E-JOURNAL 12		01		02		* INDICATE RECEIPT 02	Receipt message	19		TAXABLE SUPPLY	
PGM2 10-03-2002 09:35	Mode/date/time																																																																																																																																		
CLERK 01 000011	Clerk/consecutive No.																																																																																																																																		
PGM2.....	Program read symbol																																																																																																																																		
GROSS TOTAL 01	Gross character																																																																																																																																		
NET TOTAL 02	Net character																																																																																																																																		
CASH-INDW 03	Cash in drawer character																																																																																																																																		
CHARGE-INDW 04	Charge in drawer character																																																																																																																																		
CREDIT-INDW 05																																																																																																																																			
CE-CASH 1 07	Foreign currency cash 1 character																																																																																																																																		
CE-CHECK 1 08	Foreign currency check 1 character																																																																																																																																		
CE-CHECK 2 09																																																																																																																																			
TAX-AMT 1 11	Taxable amount 1 character																																																																																																																																		
TAX 1 12	Tax 1 character																																																																																																																																		
TAX-AMT 2 13																																																																																																																																			
T 14																																																																																																																																			
ROUNDING AMT 22	Rounding character																																																																																																																																		
CANCEL TTL 23	Cancellation total character																																																																																																																																		
RF-MODE TTL 24	Refund mode total character																																																																																																																																		
COMMISSION 25																																																																																																																																			
CALCULATOR 27																																																																																																																																			
NON-LINK DPT 28	Non link department character																																																																																																																																		
CASH 01	Cash key descriptor																																																																																																																																		
CHECK 05	Check key descriptor																																																																																																																																		
PD 06	Paid out key descriptor																																																																																																																																		
R ON/OFF 07	Receipt on/off key descriptor																																																																																																																																		
TL 09																																																																																																																																			
CHARGE 10																																																																																																																																			
RC 11	Received on account key descriptor																																																																																																																																		
VAT 12																																																																																																																																			
FX 43																																																																																																																																			
- 63																																																																																																																																			
PRICE 63																																																																																																																																			
P/G RCT 66																																																																																																																																			
%+ 67																																																																																																																																			
%- 68																																																																																																																																			
OPEN 69																																																																																																																																			
DEPT01 01	Department 1 key character																																																																																																																																		
DEPT02 02	Department 2 key character																																																																																																																																		
DEPT23 03																																																																																																																																			
DEPT24 24	Department 24 key character																																																																																																																																		
CLERK 01 01	Clerk 01 character																																																																																																																																		
CLERK 02 02	Clerk 02 character																																																																																																																																		
CLERK 03 03																																																																																																																																			
CLERK 14 14																																																																																																																																			
CLERK 15 15	Clerk 15 character																																																																																																																																		
GRND TTL 01	Grand total character																																																																																																																																		
. @NoQT 01																																																																																																																																			
NoCT 02																																																																																																																																			
X / 03																																																																																																																																			
T1T2T3T4 04	Special character																																																																																																																																		
05																																																																																																																																			
06																																																																																																																																			
07																																																																																																																																			
DAILY 01																																																																																																																																			
PLU 02																																																																																																																																			
HOURLY 03																																																																																																																																			
PERIODIC 04	Report header																																																																																																																																		
10																																																																																																																																			
11																																																																																																																																			
E-JOURNAL 12																																																																																																																																			
01																																																																																																																																			
02																																																																																																																																			
* INDICATE RECEIPT 02	Receipt message																																																																																																																																		
19																																																																																																																																			
TAXABLE SUPPLY																																																																																																																																			

# To print the print control, compulsory clerk program (except PLU)

## OPERATION

## REPORT

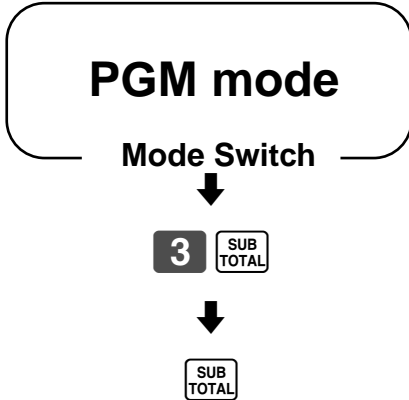

PGM3 10-03-2002 09:40	Mode/date/time
CLERK 01 000012	Clerk/consecutive No.
PGM3 .....	Program read symbol
0122 00000022	General control
0222 00000001	
0422 00000000	
0522 00000110	
0622 00000004	
1822 00001000	
2122 00000000	
2922 00000000	
0125	Tax table 1
	6%
	0000
	5002
0225	Tax table 2
	5%
	0000
	5002
0325	Tax table 3
	10%
	0000
	5003
CLERK 01 01	Clerk name
00 0001	Clerk program
CLERK 02 02	
00 0002	
CLERK 15 01	
00 0015	
DEPT01 01	Dept. descriptor/Dept. No.
0000000000 @1.00	Sales status/unit price *1
DEPT02 02	
0000000000 @2.00	
DEPT24 01	
0000000000 @24.00	
CASH 00002100	Cash key program
CHECK 00000000	Check key program
PD 00000100	
00000000	
%-	
OPEN 00000000	

\*1 Departments without being programmed are not printed on this report.

# Troubleshooting

This section describes what to do when you have problems with operation.

## When an error occurs

Errors are indicated by an error tone. When this happens, you can usually find out what the problem is as shown below.

Does the display show an error code?

No	Yes			
↓	↓	Error code (Message)	Meaning	Action
↓		<b>E01</b> (ERR-MODE)	Mode switch position changed before finalization.	Return the mode switch to its original setting and finalize the operation.
↓		<b>E08</b> (SIGN-ON)	Registration without entering a clerk number.	Enter a clerk number.
↓		<b>E10</b> (PRNT-LID)	Platen arm of the printer is opened.	Close the platen arm.
↓		<b>E11</b> (DRW-OPEN)	Registration is made while cash drawer is opened.	Close the cash drawer.
↓		<b>E12</b> (JPAP-END)	Journal paper end	Replace the new paper roll.
↓		<b>E14</b> (RPAP-END)	Receipt paper end	Replace the new paper roll.
↓		<b>E27</b> (BUF-FULL)	Transaction cancel buffer full.	Finalize the transaction.
↓		<b>E31</b> (PRESS-ST)	Finalization of a transaction attempted without confirming the subtotal.	Press the  key.
↓		<b>E33</b> (TEND-AMT)	Finalize operation attempted without entering amount tender.	Enter the amount tendered.
↓		<b>E35</b> (CNG-OVER)	Change amount exceeds preset limit.	Input amount tendered again.
↓		<b>E38</b> (DECL-AMT)	Read/reset operation without declaring cash in drawer. This error appears only when this function is activated.	Perform money declaration.
↓				

Press  key and check the appropriate section of this manual for the operation you want to perform.

## When the register does not operate at all

Perform the following check whenever the cash register enters an error condition as soon as you switch it on. The results of this check are required by service personnel, so be sure to perform this check before you contact a CASIO representative for servicing.

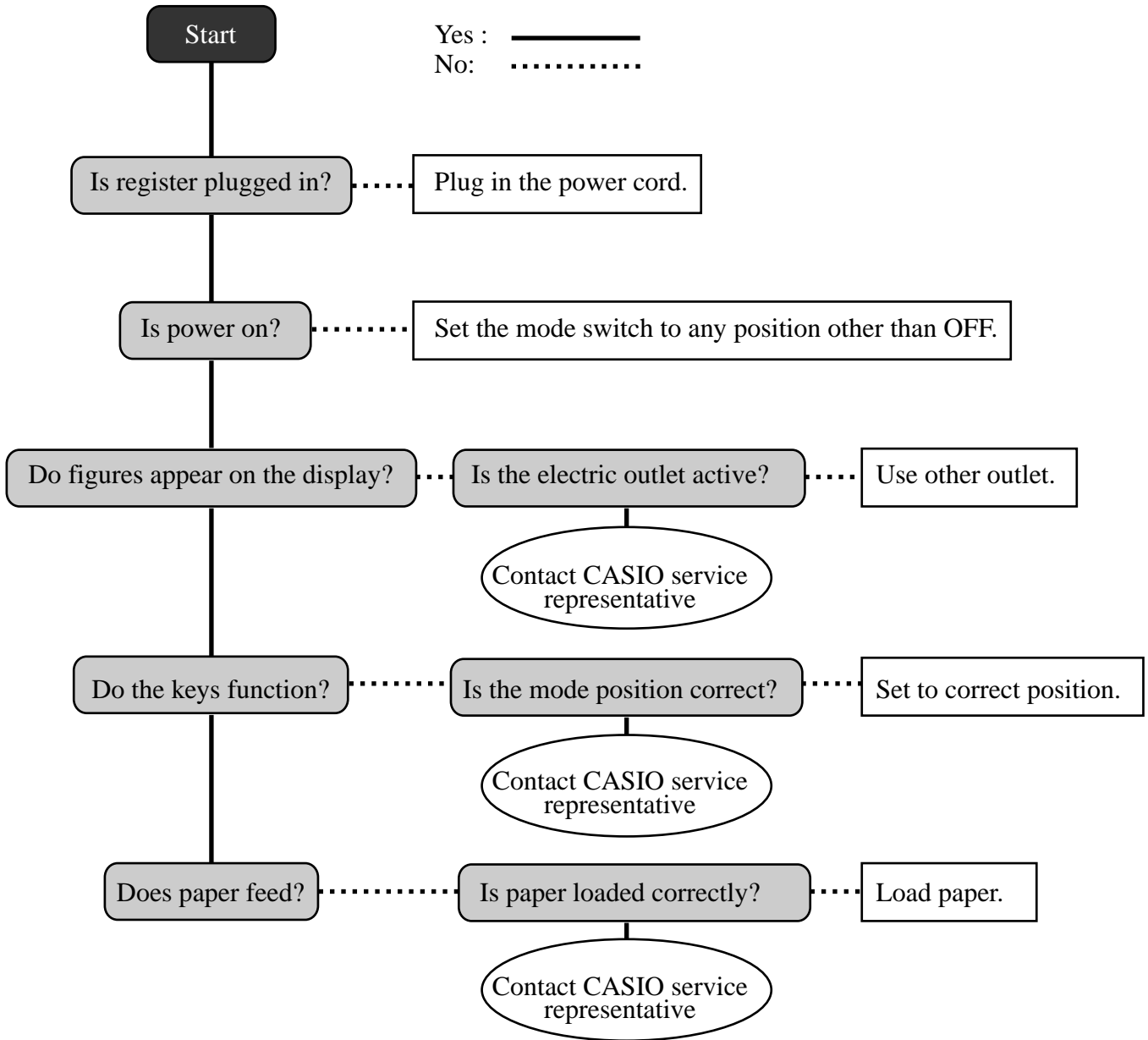

## In case of power failure

If the power supply to the cash register is cut by a power failure or any other reason, simply wait for power to be restored. The details of any ongoing transaction as well as all sales data in memory are protected by the memory backup batteries.

- Power failure during a registration  
The subtotal for items registered up to the power failure is retained in memory. You will be able to continue with the registration when power is restored.
- Power failure during printing a read/reset report  
The data already printed before the power failure is retained in memory. You will be able to issue a report when power is restored.
- Power failure during printing of a receipt and the journal  
Printing will resume after power is restored. A line that was being printed when the power failure occurred is printed in full.
- Other  
The power failure symbol is printed and any item that was being printed when the power failure occurred is reprinted in full.

### Important!

Once receipt/journal printing or printing of a report starts, it can be stopped only by interruption of power to the cash register.

## When the L sign appears on the display

### About the low battery indicator...

The following shows the low battery indicator.



If this indicator appears when you switch the cash register on, it can mean one of three things:

- No memory backup batteries are loaded in the cash register.
- The power of the batteries loaded in the unit is below a certain level.
- The batteries loaded in the unit are dead.

To clear this sign, press  key.

### Important!

Whenever the low battery indicator appears on the display, load a set of three new batteries as soon as possible. If there is a power failure or you unplug the cash register when this indicator appears, you will lose all of your sales data and settings.

**BE SURE TO KEEP THE POWER CORD OF THE CASH REGISTER  
PLUGGED IN WHENEVER YOU REPLACE THE BATTERIES.**

## To replace journal paper

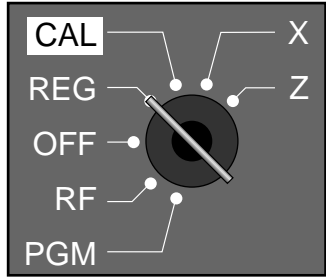

### Step 1

Set the mode switch to the REG position and remove the printer cover.



### Step 2

Press **JOURNAL FEED** to feed about 20 cm of paper.



### Step 6

Slide the printed journal from the take-up reel.



### Step 3

Cut the journal paper at the point where nothing is printed.



### Step 7

Open the platen arm.



### Step 4

Remove the journal take-up reel from its holder.



### Step 8

Remove the old paper roll from the cash register.



### Step 5

Remove the paper guide from the take-up reel.

### Step 9

Load new paper.

Go to the step 3 described on page 10 of this manual.

## To replace receipt paper



### Step 1

Set the mode switch to the REG position and remove the printer cover.

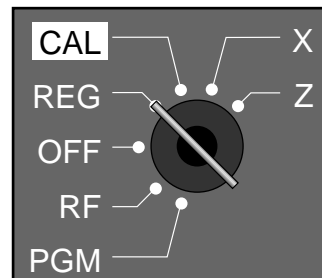

### Step 2

Open the platen arm.



### Step 3

Remove the old paper roll from the cash register.

### Step 4

Load new paper.

Go to the step 3 described on page 9 of this manual.

#### NOTE:

After completion of register programming, enter **6 2 0 0** and **SUB TOTAL** in the PGM 3 mode (PGM mode ⇒ **3** **SUB TOTAL**) to backup the program data into the internal non-volatile memory. (This operation takes about 10 seconds.)

## Options

### WT-82 wetproof cover

The optional wetproof cover protects the keyboard from moisture damage.

Consult your CASIO dealer for details.

# Specifications

## Input method

Entry: 10-key system; Buffer memory 8 keys (2-key roll over)  
 Department: Full key system

## Display

Amount 8 digits (Zero suppression) ; No. of repeats, Receipt On/Off  
 Character 8 digits; Item descriptor, Key descriptor, Mode

## Printer

Printer: Dot matrix thermal printer (Receipt and journal printing)  
 24 digits (Amount 10 digits/descriptor 8, 12 or 24 digits)  
 Journal: Automatic take up roll winding  
 Print speed: Max. 14 lines/sec.  
 Feed speed: Max. 14 lines/sec.  
 Paper roll: 58 mm × 80 mm Ø (Max.)  
 CASIO P-5880T

## Calculations

Entry 8 digits; Registration 7 digits; Total 8 digits

## Chronological data

Date print: Automatic date printout on receipt and journal  
 Automatic calendar  
 Time print: Automatic time printout on receipt and journal  
 Time display: 24-hour system

## Alarm

Entry confirmation signal; Error alarm

## Totalizers

Category	No. of Totalizers	Contents				Periodic Totalizer
		Amount (10 digits)	No. of items (4 digits)	Count (4 digits)	No. of customers (4 digits)	
Department	24	✓	✓*1			✓
PLU	1500	✓	✓*1			
Hourly sales	24	✓			✓	
Monthly	31	✓			✓	
Clerk	15	✓			✓	
Transaction	33	✓ or	✓ or	✓ or	✓	✓
Non resettable grand sales total	1	✓*2				
Reset counter	6			✓		✓
Consecutive No.	1			✓		

\*1: 4 digit integer + 2 digit decimal, \*2: 12 digits

## Memory protection batteries

The effective service life of the memory protection batteries (three new SUM-3 or UM-3 type batteries) is approximately one year from installation into the machine.

## Power supply/ Power consumption

As noted on the plate affixed to right side of register.

## Operating temperature

0°C ~ 40°C

## Humidity

10 ~ 90%

## Dimensions and Weight

291mm (H) × 410mm (W) × 474mm (D)/11kg ..... with medium size drawer

The CE marking below applies to the EU region. Declarer of conformity is as follows:



Casio Electronics Co., Ltd.  
 Unit 6, 1000 North Circular Road  
 London NW2 7JD, U.K.

\* Specifications and design are subject to change without notice.

## A

alphabet keys 53  
arithmetic operation key 21  
Australian rounding 15

## B

backspace/character code fixed key 53  
bottom message 22

## C

CAL mode 18  
calculator mode 18, 21, 67  
cancel 20, 40  
CAPS key 53  
cash amount tendered key 21  
change preparation 24  
character code list 54  
character enter key 53  
character entering 53  
character fixed key 53  
character keyboard 53  
charge 21, 34  
check 21, 34  
clear 20, 38  
clear/all clear key 21  
clerk control function 42  
clerk name 48, 49  
clerk number 47  
clerk sign on and sign off 42  
commercial message 22  
consecutive No. range 47  
consecutive number 22  
correction 38  
credit balance 67  
currency exchange 20, 62  
customer display 17, 19

## D

daily sales report 41, 73  
Danish rounding 15, 65  
date setting 12  
daylight saving time 68  
decimal symbol 45  
department 19, 20, 25, 26, 48, 55, 69, 73, 76  
department link 56  
digit separator symbol 45  
discount (percent) 20, 30  
display 17, 19  
displaying the time 24  
displaying the time and date 24  
double size letter key 53  
drawer 17, 18  
drawer key 17  
drawer lock 17  
drawer open key 21  
drawer release lever 18

## E

equal 21  
error code 78  
error correct 20, 39

## F

feed key 20  
financial report 70  
force entry of the amount tendered 65

## G

grand-sales total 40, 73  
group link 57, 59

## H

hash department 54, 56, 59  
high amount limit 65, 67  
high amounts limit 65  
high digit limit 54, 56, 59, 67

## I

item counter 22

## J

journal 22  
journal compressed print 45  
journal skip 22, 45

## K

key descriptor 48, 52  
keyboard 17, 20

## L

L sign 80  
logo message 22  
low battery indicator 80

## M

machine number 47  
main display 17, 19  
memory recall 21, 67  
message 22  
minus (reduction) 20, 32  
mode key 17  
mode switch 17, 18  
money declaration 44, 70, 73  
multiplication 20, 25, 29  
multipurpose tray 17, 18

## N

negative department 54, 56, 59  
no sale 20, 40  
non-add 20, 34  
non-resettable grand total 40, 73

- O**
- open 20, 59
  - operator display 17, 19
  - operator key 17
- P**
- paid out 37
  - paper feed key 20
  - paper installation 9
  - paper loading 9
  - paper replacement 81, 82
  - percent 20, 30
  - periodic report 74
  - PGM mode 18
  - PLU 20, 28, 29, 51, 57, 69, 71, 75
  - pop-up display 17, 19
  - post receipt 20, 43
  - power failure 80
  - preset price 26, 27, 28
  - price 20, 60
  - print subtotal 45
  - print tax rate with tax totalizer 47
  - print the sales ratio 47
  - print VAT breakdown 65
  - printer 17
  - printer cover 17
  - program end key 53
  - program key 17
  - program mode 18
  - program read 75, 76, 77
  - prohibit cancel operation 44
- R**
- read mode 18
  - read report 69, 70, 71, 72, 73, 74
  - receipt message 50
  - receipt on/off indicator 19
  - received on account 21, 37
  - reduction (minus) 20, 32
  - refund (return) 35, 36
  - refund mode 18
  - REG mode 18
  - register mode 18
  - repeat 19, 25, 29, 60
  - report descriptor 48
  - report title 48, 49
  - reset mode 18
  - reset report 41, 69, 71, 72, 73, 74
  - reset the consecutive number 44
  - return 35, 36
  - RF mode 18
  - roll paper installation 9
  - roll paper specification 83
  - rounding 15
  - rounding (Australian rounding) 15
  - rounding (Danish rounding) 15
  - rounding (special rounding) 15
- S**
- shift key 53
  - sign off 42
  - sign on 42
  - single item sale 25, 29, 54, 57, 59, 60
  - skip zero total lines 47
  - space key 53
  - special rounding 15
  - stand-by mode 18
  - store number (machine number) 46
  - subdepartment 56, 59, 60
  - subtotal 21, 25
- T**
- take-up reel 17
  - tax calculation 27
  - tax status 26, 28, 30, 32
  - tax table programming 13, 15
  - ten key pad 20
  - time setting 12
  - time system (12/24Hr) 45
  - training clerk 47, 73, 74
- V**
- VAT 61
- X**
- X mode 18
  - X report (read report) 69, 70, 71, 72, 73, 74
- Z**
- Z mode 18
  - Z report (reset report) 41, 69, 71, 72, 73, 74





**CASIO®**

**CASIO COMPUTER CO., LTD.**  
6-2, Hon-machi 1-chome  
Shibuya-ku, Tokyo 151-8543, Japan

MO0201-A Printed in Indonesia

TE-2000\*E

Printed on recycled paper.